



BEST OF FEIN POWER TOOLS & EQUIPMENT CATALOG



OSCILLATING

Trusted by professionals in the interior construction, flooring, renovation, carpentry, plumbing, tiling, woodworking, boat maintenance and restoration industries for over 50 years!



PERFORMANCE
CLASS

MULTIMASTER 500

ALL AROUND GREAT PERFORMANCE

MADE IN
GERMANY

- + Long-life, 350 watt German-made motor
- + Variable speed control optimizes cutting performance
- + Best in class vibration dampening
- + StarlockPlus blade mount so you can choose from over 160 Starlock and StarlockPlus accessories
- + Ultra fast QuickIN blade change
- + Oscillating range: 2 x 1.7°



MULTIMASTER 500

Power consumption (corded version)	W	350
Battery (cordless version)	V	18
Battery capacity	Ah	2.0 or 4.0
Oscillations	OPM	11,000 - 18,500
Amplitude		2 x 1.7°
Tool mounting		Starlock/StarlockPlus
Tool change		QuickIN



Powered by



BOSCH



CORDLESS MULTIMASTER 500



18V CORDLESS MULTIMASTER 500 PLUS KIT 2 Ah

PART NUMBER: 71293865090

KIT INCLUDES: 1 AMM500, 1 2Ah CORE 18V battery, 1 Fast charger, 18 accessories, 1 nylon bag



18V CORDLESS MULTIMASTER 500 PLUS KIT 4 Ah

PART NUMBER: 71293866090

KIT INCLUDES: 1 AMM500, 1 4Ah CORE 18V battery, 1 Fast charger, 18 accessories, 1 nylon bag



18V CORDLESS MULTIMASTER 500 SELECT

PART NUMBER: 71293862090

SELECT TOOL BUNDLE INCLUDES: 1 AMM500, 1 accessory, 1 L-BOXX pro tool case



18V CORDLESS MULTIMASTER 500 TOP KIT 4Ah

PART NUMBER: 71293861090

KIT INCLUDES: 1 AMM500, 2 4Ah CORE 18V batteries, 1 Fast charger, 31 accessories, 1 L-BOXX pro tool case

CORDED MULTIMASTER 500



MULTIMASTER MM 500 START

PART NUMBER: 72295264090

KIT INCLUDES: 1 MM 500, 24 accessories, 1 nylon tool case



MULTIMASTER MM 500 PLUS TOP

PART NUMBER: 72296770090

KIT INCLUDES: 1 MM 500, 31 accessories, 1 L-BOXX pro tool case



MULTIMASTER MM 500 PLUS BASIC

PART NUMBER: 72296769090

KIT INCLUDES: 1 MM 500, 1 accessory, 1 L-BOXX pro tool case

OSCILLATING

Trusted by professionals for tougher jobs requiring higher power on a daily basis in the interior construction, flooring, renovation, carpentry, plumbing, tiling, woodworking, boat maintenance, and restorations industries for over 50 years!



PERFORMANCE
CLASS

MULTIMASTER 700

THE PRO'S CHOICE

MADE IN
GERMANY

- + Long-life, 450 watt German-made motor
- + Widest range of variable speed control for precise control
- + StarlockMax blade mount: flexibility to choose from over 180 Starlock, StarlockPlus, and StarlockMax accessories
- + Oscillating range: 2 x 2.0° for faster cutting performance
- + Best in class vibration dampening
- + Ultra fast QuickIN blade change



MULTIMASTER 700

Power consumption (corded version)	W	450
Battery (cordless version)	V	18
Battery capacity	Ah	4.0
Oscillations	OPM	10,000 - 19,500
Amplitude		2 x 2.0°
Tool mounting		Starlock/StarlockPlus/ StarlockMax
Tool change		QuickIN



Powered by



BOSCH



CORDLESS MULTIMASTER 700



18V CORDLESS MULTIMASTER 700 SELECT

PART NUMBER: 71293662090

SELECT TOOL BUNDLE INCLUDES: 1 AMM700,
1 accessory, 1 L-Boxx pro tool case



18V CORDLESS MULTIMASTER 700 PLUS KIT 4 Ah

PART NUMBER: 71293664090

KIT INCLUDES: 1 AMM700, 1 4Ah CORE 18V battery,
1 Fast charger, 18 accessories, 1 nylon bag



18V CORDLESS MULTIMASTER 700 MAX TOP KIT 4Ah

PART NUMBER: 71293661090

KIT INCLUDES: 1 AMM700, 2 4Ah CORE 18V batteries, 1 Fast charger,
60 accessories, 1 L-Boxx pro tool case

CORDED MULTIMASTER 700



MULTIMASTER MM 700 MAX BASIC

PART NUMBER: 72296863090

KIT INCLUDES: 1 MM 700, 1 accessory, 1 L-Boxx pro
tool case



MULTIMASTER MM 700 MAX TOP

PART NUMBER: 72296864090

KIT INCLUDES: 1 MM 700, 31 accessories, 1 L-Boxx pro
tool case

OSCILLATING ACCESSORIES

FEIN offers the right solution for thousands of professional applications, for all FEIN oscillating multi-tools and the most common multifunctional tools on the market. Find the perfect accessory that is right for your project.

STARLOCK FITS THE MOST BRANDS OF ANY OSCILLATING PLATFORM.



STARLOCK

● Fits ● Fits but requires adapter ● Does not fit

Bosch - 2015 & Newer - Starlock	●
FEIN Starlock Models	●
Festool	●
Flex	●
Makita - 2021 & Newer (cordless)	●
Metabo - 2021 & Newer	●
Bauer	●
Bosch - Pre 2015 - OIS Interface	●
Craftsman - Pre 2019	●
FEIN - All Legacy Models - Pre 2015	●
Hitachi (Now Metabo HPT)	●
Kobalt	●
Makita - Pre 2021 Non-Starlock	●
Metabo - Pre 2020	●
Milwaukee	●
Ridgid	●
Rockwell	●
Ryobi	●
Skill	●
Worx	●
Craftsman - 2020 & Newer	●
DeWalt	●
Porter Cable	●
FEIN - Legacy Supercut Models - Pre 2015	●
Dremel	●

Achieve precise, high-quality cuts at top speeds with our German engineered blades. Designed to fit a variety of oscillating multitools, Starlock blades will help you get the most out of your multitool.



STARLOCK BLADES OFFER THE QUICKEST & SAFEST BLADE CHANGE SYSTEM!



To release the blade, lift the locking lever...



Blade will simply drop out. Close the locking lever...



then simply position the new blade in the Starlock mount & click into place. **Ready to go!**

NEVER TOUCH A HOT BLADE AGAIN!



GENERAL PURPOSE BLADES



E-CUT PRECISION BIM SAW BLADE

Bi-metal with double-row of HSS Japanese teeth for all wood materials, drywall and soft plastics. Fastest cutting speed and maximum precision.



E-CUT STANDARD - CURVED

Set teeth for all wood, drywall and plastic materials. Curved geometry for optimal plunge cutting.



E-CUT LONG LIFE

Bi-metal with HSS teeth for all wood, drywall and plastic materials. Robust and resistant to nails in wood, masonry, etc.



E-CUT UNIVERSAL

Bi-metal with wavy HSS universal teeth. For sheet metal up to 1/16 in, aluminum, copper pipes, wood, drywall and plastics.



E-CUT CARBIDE PRO

Wear-resistant carbide teeth for hard metals such as tempered screws and high-strength machine screws. Also for abrasive materials such as brick, masonry, cement fiber slabs & laminate.

MULTI-MATERIAL BLADES

MADE IN GERMANY

Part Number	Description	Blade Width	Pack Size	Blade Type
63502106210	Saw blade SL segmented HSS	3-11/32"	1	3/4 Round - Clean Wood
63502176210	Saw blade SLP round wood BIM	3-15/16"	1	RND - Multi Material
63502205260	Saw blade SL E-Cut precision BIM	1-3/8"	1	JPN Tooth Multi Material
63502205270	Saw blade SL E-Cut precision BIM	1-3/8"	3	JPN Tooth Multi Material
63502205290	Saw blade SL E-Cut precision BIM	1-3/8"	10	JPN Tooth Multi Material
63502229260	Saw blade SL E-Cut precision BIM	2-1/2"	1	JPN Tooth Multi Material
63502229270	Saw blade SL E-Cut precision BIM	2-1/2"	3	JPN Tooth Multi Material
63502229290	Saw blade SL E-Cut precision BIM	2-1/2"	10	JPN Tooth Multi Material
63502227260	Saw blade SL E-Cut curved HCS	1-3/8"	1	Curved - Wood/Drywall
63502227270	Saw blade SL E-Cut curved HCS	1-3/8"	3	Curved - Wood/Drywall
63502225260	Saw blade SL E-Cut curved HCS	2-1/2"	1	Curved - Wood/Drywall
63502225270	Saw blade SL E-Cut curved HCS	2-1/2"	3	Curved - Wood/Drywall
63502225290	Saw blade SL E-Cut curved HCS	2-1/2"	10	Curved - Wood/Drywall

DEMO BLADES

MADE IN GERMANY

Part Number	Description	Blade Width	Pack Size	Blade Type
63502184270	Saw blade SL E-Cut Long Life BIM	3/8"	3	All Material Demo
63502183290	Saw blade SL E-Cut Long Life BIM	3/8"	10	All Material Demo
63502160260	Saw blade SL E-Cut Long Life BIM	1-3/8"	1	All Material Demo
63502160270	Saw blade SL E-Cut Long Life BIM	1-3/8"	3	All Material Demo
63502160290	Saw blade SL E-Cut Long Life BIM	1-3/8"	10	All Material Demo
63502221260	Saw blade SL E-Cut Long Life BIM	2"	1	All Material Demo
63502221270	Saw blade SL E-Cut Long Life BIM	2"	3	All Material Demo
63502228260	Saw blade SL E-Cut Long Life BIM	2-1/2"	1	All Material Demo
63502228270	Saw blade SL E-Cut Long Life BIM	2-1/2"	3	All Material Demo
63502228290	Saw blade SL E-Cut Long Life BIM	2-1/2"	10	All Material Demo
63502161270	Saw blade SLP E-Cut Long Life BIM	2-1/2"	3	All Material Demo
63502161290	Saw blade SLP E-Cut Long Life BIM	2-1/2"	10	All Material Demo

METAL CUTTING BLADES

MADE IN GERMANY

Part Number	Description	Blade Width	Pack Size	Blade Type
63502152260	Saw blade SLP E-Cut Universal BIM	1-3/4"	1	Metal/Universal
63502152270	Saw blade SLP E-Cut Universal BIM	1-3/4"	3	Metal/Universal
63502152290	Saw blade SLP E-Cut Universal BIM	1-3/4"	10	Metal/Universal
63502223260	Saw blade SL E-Cut Universal BIM	1-3/4"	1	Metal/Universal
63502223270	Saw blade SL E-Cut Universal BIM	1-3/4"	3	Metal/Universal
63502223290	Saw blade SL E-Cut Universal BIM	1-3/4"	10	Metal/Universal
63502157260	Saw blade SL E-Cut Fine	1-1/8"	1	FINE Metal
63502157270	Saw blade SL E-Cut Fine	1-1/8"	3	FINE Metal
63502157290	Saw blade SL E-Cut Fine	1-1/8"	10	FINE Metal
63502236260	Saw blade SL E-Cut metal Carbide Pro	1-1/4"	1	Heavy/Hard Metal
63502236270	Saw blade SL E-Cut metal Carbide Pro	1-1/4"	3	Heavy/Hard Metal
63502236290	Saw blade SL E-Cut metal Carbide Pro	1-1/4"	10	Heavy/Hard Metal

OSCILLATING ACCESSORIES

FEIN offers the right solution for thousands of professional applications, for all FEIN oscillating multi-tools and the most common multifunctional tools on the market. Find the perfect accessory that is right for your project.

OMT ACCESSORIES



Part Number	Description
92602102000	Dust extraction accessory set, fits current 300, 500 & 700 series tools
32127069010	Depth stop for StarLock blades

SPECIALTY BLADES



Part Number	Description	Pack Size	Blade Type
63502118210	SL Saw blade Segmented	1	Grout/Tile
63731001210	SL Rasp triangle shape TC 80	1	Grout/Tile
63731002210	SLP Rasp finger shape TC	1	Grout/Tile
63903165210	SL Flexible scraper	1	Scraping Soft Material
63903226210	SL Rigid scraper blade	1	Scraping Hard Material
63903245230	SL Cutter blade mushroom	5	Caulk Removal
63903251260	SL Multi Blade	1	Roofing/Vinyl
63706019210	SL File TC	1	Carbon Fiber/Wood
63502114210	Segmented Diamond Saw Blade	1	Hard Grouts/Epoxy Resin

EXTREME PERFORMANCE CARBIDE & DIAMOND BLADES*



DIAMOND SAW BLADE

The especially robust saw blade with a long service life for extremely hard epoxy materials, including waterproof epoxy resin grouts in swimming pools.



CARBIDE SAW BLADE

The economical alternative for removing marble, epoxy resin, and trass joints, cutting grooves in plaster, porous concrete, and similar construction materials.

Part Number	Description	Pack Size	Blade Type
63903241210	Carbide Grit - Special Shape	1	Grout/Tile
63903243210	Diamond Grit - Special Shape	1	Hard Grouts/Epoxy Resin

***For use with (A)MM700 tools only**



NEW!

EXTREME PERFORMANCE BLADES*

MADE IN GERMANY



Part Number	Description	Blade Width	Pack Size	Blade Type
63502203220	3" XL SLM E-Cut Long Life blade BIM	1-5/8"	3	XL Reach Demo
63502203240	3" XL SLM E-Cut Long Life blade BIM	1-5/8"	10	XL Reach Demo
63502224260	3-1/2" SLM XL E-Cut Long Life blade BIM	1-1/4"	1	XXL Reach Demo
63502224290	3-1/2" SLM XL E-Cut Long Life blade BIM	1-1/4"	10	XXL Reach Demo
63502238220	3" Saw blade SLM E-Cut metal Carbide Pro	1-1/4"	3	XL Reach Hard Metal

*For use with (A)MM700 tools only

BULK PACK BLADES

MADE IN GERMANY



Part Number	Description	Blade Width	Pack Size	Blade Type
63502160250	SL E-Cut Long Life Saw Blade	1-3/8"	50	Demo
63502223250	SL E-Cut Universal Saw Blade	1-3/4"	50	Metal/Universal
63502151250	SLP E-Cut Universal Saw Blade	1-1/8"	50	Metal/Universal
63502152250	SLP E-Cut Universal Saw Blade	1-3/4"	50	Metal/Universal

BLADE KITS



Part Number	Description	Pack Size	Blade Type
35222967010	Best of Starlock WOOD & METAL Kit	6	Wood/Metal
35222967290	Combo Starlock RENOVATION PRO	3	Reno
35222967300	E-Cut Combo Starlock WOOD	3	Wood
35222967060	Best of Starlock RENOVATION	26	Reno
35222952140	E-Cut saw blade Combo SL 3-Pack	3	Wood/Metal
35222942080	Best of E-Cut SLP WOOD & METAL	6	Wood/Metal

NEW!



STARLOCK L-BOXX OMT ACCESSORY SET

PART NUMBER: 33903750010

KIT INCLUDES: 34 piece accessory set containing:
 3 E-Cut bi-metal Japanese tooth blades, 3 E-Cut bi-metal universal tooth blades, 2 segmented saw blades, 1 sanding pad with 25 sheets of sandpaper, 1 L-Boxx pro tool case



SANDING ACCESSORIES

FEIN oscillating offers a vast product range for sanding to fit hundreds of applications. Project finishing starts with FEIN MULTIMASTER

SANDING - STANDARD 3-1/8"



BACKING PAD

Standard version SL. Triangular shape, hook and loop surface. 2 piece

PART NUMBER:

63806129220



BACKING PAD

Narrow, flat. SL Triangular shape, hook and loop surface. 2 piece

PART NUMBER:

63806142220



BACKING PAD

For special applications such as cleaning alloy auto wheels and paint repairs. SL Triangular shape, hook and loop surface. 2 piece

PART NUMBER:

63806141220



BACKING PAD

Standard version with dust extraction. SL Triangular shape, hook and loop surface. 2 piece

PART NUMBER:

63806136220



SANDING SHEETS, "STONE"

Specifically for sanding natural and artificial stone. For perfect surface finishing in fine finish, available up to 800 grit. Unperforated, hook and loop attachment.

Part Number	Piece	Grit
63717120014	50	40
63717121013	50	80
63717122016	50	120
63717123010	50	220
63717124018	50	320
63717125012	50	400
63717175017	50	600
63717176010	50	800



SANDING SHEETS

Aluminum oxide and full resin bond guarantee fast material removal. Unperforated, hook and loop attachment.

PartNumber	Piece	Grit
63717086048	5	36
63717086010	50	36
63717081046	5	40
63717081018	50	40
63717082049	5	60
63717082011	50	60
63717083043	5	80
63717083015	50	80
63717084041	5	100
63717084013	50	100
63717085045	5	120
63717085017	50	120
63717087042	5	150
63717087014	50	150
63717088040	5	180
63717088012	50	180
63717089044	5	220
63717089016	50	220
63717090046	5	240
63717090018	50	240



SANDING SHEETS

Aluminum oxide and full resin bond guarantee fast material removal. Perforated version, hook and loop surface.

Part Number	Piece	Grit
63717107049	5	36
63717107011	50	36
63717108047	5	40
63717108019	50	40
63717109041	5	60
63717109013	50	60
63717110043	5	80
63717110015	50	80
63717111042	5	100
63717111014	50	100
63717112045	5	120
63717112017	50	120
63717113049	5	150
63717113011	50	150
63717114047	5	180
63717114019	50	180
63717115041	5	220
63717115013	50	220
63717116044	5	240
63717116016	50	240



SANDING SHEETS, ZIRCONIUM

Unrivaled removal rate on extremely hard surfaces such as clear coats or metal. Perforated, hook and loop attachment.

Part Number	Piece	Grit
63717236010	35	40
63717237010	35	60
63717238010	35	80



SANDING SHEETS, ZIRCONIUM

For special applications such as cleaning alloy auto wheels and paint repairs. Use only in combination with backing pad 63806141026. Unperforated, hook and loop attachment.

Part Number	Piece	Grit
63717126015	50	240
63717127019	50	320
63717128017	50	400
63717179016	50	500



SANDING SHEETS, ZIRCONIUM

Unrivaled removal rate on extremely hard surfaces such as clear coats or metal. Unperforated, hook and loop attachment.

Part Number	Piece	Grit
63717243010	35	40
63717244010	35	60
63717245010	35	80



ASSORTED SANDING SHEET SET

50 sanding sheets in various grits. Price includes: 10 of each type (60, 80, 120, 180, 240 grit), unperforated, with hook and loop attachment.

PART NUMBER:
63717082033



ASSORTED SANDING SHEET SET

50 sanding sheets in various grits. Price includes: 10 of each type (60, 80, 120, 180, 240 grit), perforated, with hook and loop attachment.

PART NUMBER:
63717109035



BACKING PAD

For use in very narrow and hard-to-reach spots in channels, grooves, openings and rabbets. Finger shape, hook and loop surface. SL mount, 2 piece.

PART NUMBER:
63806159220



SANDING FINGER SHEETS

Hook & Loop, full synthetic resin bonding, high performance, aluminum oxide. Applications, wood, metal, solder joints, GFRP, plastic, paint, filler and leather.

Part Number	Piece	Grit
63717184012	20	40
63717185016	20	60
63717186019	20	80
63717187013	20	100
63717188011	20	120
63717189015	20	150
63717190017	20	180
63717191016	20	220
63717192019	20	240



SANDING DISC SET W/BACKING PAD

Fast, efficient sanding, the alternative to random orbit sanders. Can be used with or without dust extraction. SLP 4-1/2 in dia., perforated version, hook and loop surface., 2 sanding sheets 60, 80, 180 grit each

PART NUMBER:
63806195210



SANDING DISC SET - REPLACEMENT PAPER

16 sanding sheets in various grits from coarse to fine. Can be used with or without dust extraction. Perforated version, hook and loop surface., 4 sanding sheets 60, 80, 180 grit each

PART NUMBER:
63717227010

SANDING ACCESSORIES

FEIN oscillating offers a vast product range for sanding to fit hundreds of applications. Project finishing starts with FEIN MULTIMASTER



SANDING SHEETS

Aluminum oxide and full resin bond guarantee fast material removal. 4-1/2 in dia., perforated version, hook and loop surface, or use with or without dust extraction system.

Part Number	Piece	Grit
63717230020	16	40
63717227020	16	60
63717228020	16	80
63717229010	16	120
63717231020	16	180
63717232010	16	240



SANDING SHEETS, ZIRCONIUM

Unrivaled removal rate on extremely hard surfaces such as clear coats or metal. 4-1/2 in dia., perforated version, hook and loop surface, or use with or without dust extraction system.

Part Number	Piece	Grit
63717233010	12	40
63717234010	12	60
63717235010	12	80

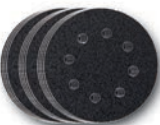

SANDING SHEETS, ZIRCONIUM

Unrivaled removal rate on extremely hard surfaces such as clear coats or metal. 4 of each type of Dia. 4-1/2 in sanding sheet (40, 60, 80 grit), perforated, for use with or without dust extraction system, hook and loop attachment.

PART NUMBER:
63717233020



LARGE SANDING SHEETS, ZIRCONIUM

Fits large triangular 5-1/8 in backing pad with. Aluminum oxide and full resin bond guarantee fast material removal, minimum glazing and long tool life. Perforated, for use with perforated backing pad and dust extraction system, hook and loop attachment.

Part Number	Piece	Grit
63717298010	12	40
63717299010	12	60
63717300010	12	80

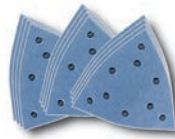

LARGE SANDING SHEET SET, ZIRCONIUM

12 sanding sheets with an unrivaled removal rate on extremely hard surfaces such as clear coats (e.g. parquet finishes) or metal. 4 of each type of Dia. 5-1/8 in sanding sheet (40, 60, 80 grit), perforated, for use with or without dust extraction, hook and loop attachment.

PART NUMBER:
35222952110



ASSORTED LARGE SANDING SHEET SET

16 abrasive sheets in various grits for universal use from coarse to fine grinding on almost any material. 4 of each type of Dia. 5-1/8 in sanding sheet (60, 80, 120, 180 grit), perforated, for use with or without dust extraction system, hook and loop attachment.

PART NUMBER:
35222952100



LARGE SANDING PAD SET

For efficient sanding of edge, corner and medium-sized areas. The alternative to random orbit or pad sanders. Plastic carrier plate to prevent damage and marks on the workpiece. includes: 1 large perforated triangular SLP backing pad (5-1/8 in edge length), 2 each perforated sanding sheets, grits 60, 80, 180.

PART NUMBER:
63806204210

SANDING - LARGE FORMAT 5-1/8"



LARGE SANDING SHEETS, PERFORATED

Fits large triangular 5-1/8 in backing pad with. Aluminum oxide and full resin bond guarantee fast material removal, minimum glazing and long tool life. Perforated, for use with perforated backing pad and dust extraction system, hook and loop attachment.

Part Number	Piece	Grit
63717293020	16	60
63717294020	16	80
63717295020	16	120
63717296020	16	180
63717297020	16	240



NEW!



PROFILE SANDING SET

22-piece set for sanding in grooves and on external radii. Contents: 1 holder with 6 different profile inserts. 1x V-shape for 90° angles, 1x trapezoid shape for tongue and groove joints, 1x straight shape for profiles, 1x convex shape (large), 1x concave and 1x convex shape (small), together with 5 of each sanding sheet. grits 80, 120, and 180.

PART NUMBER:
63810031010



BEST OF SANDING ACCESSORY SET

61-piece accessory set for all sanding at corners and edges and medium to large areas in a practical plastic storage case. Contents: 1 triangular backing pad, unperforated, with 10 of each sanding sheet, grits 16, 80, 120, 180, 1 backing pad 4-1/2 in dia., with six of each sanding sheet, grits 60, 80, 180, 1 triangular carbide rasp.

PART NUMBER:
35222942040



SANDPAPER FOR PROFILE SANDING SET

Aluminum oxide and full resin bond guarantee fast material removal, minimum glazing and long tool life. For universal use on almost all materials, unperforated.

Part Number	Piece	Grit
63717217016	25	80
63717218014	25	120
63717219018	25	180



BEST OF STARLOCK SANDING SET

63-piece accessory set for sanding in corners and on edges. For use with all FEIN MultiTools and all other commercially available multi-tools with the Starlock mount. Contents: 2 sanding pads, unperforated (3-1/8 in), 1 sanding finger, 10 sanding sheets each (grits 60, 80, 120) for sanding pad and sanding finger.

PART NUMBER:
35222967280

DUST COLLECTION ACCESSORIES



DUST EXTRACTION SET - CURRENT

2 backing pads, perforated, 5 of each sanding sheet, perforated, grits 60, 80, 120, 1 extraction cap with suction tube. For MultiMaster and SuperCut (corded and cordless)

Compatible with:
MultiMaster (A)MM 500 and (A)MM 700

PART NUMBER:
92602102000

SPECIALTY OSCILLATING

The FEIN 1.7 series oscillating tool offers uncompromising performance for demanding applications and all day use.

MADE IN GERMANY

MM 700 1.7

Hex blade attachment for efficient power transmission



(A)MM 700 1.7 Q

Quick change hex blade attachment for efficient power transmission



ALL 1.7 TOOLS FEATURE

- + 2 x 1.7° Oscillations
- + German-made motor
- + Solid metal head for superior durability
- + Low vibration for all day use
- + Electronic variable speed control



18V CORDLESS MULTIMASTER 700 1.7Q AS SELECT

PART NUMBER: 71293761090

KIT INCLUDES: 1 MM700 1.7Q, 2 accessories, 1 L-Boxx pro tool case



18V CORDLESS MULTIMASTER 700 1.7Q AS AUTOGLASS

PART NUMBER: 71293762090

KIT INCLUDES: 1 AMM700 1.7Q, 2 4Ah CORE 18V batteries, 1 Fast charger, 14 accessories, 1 L-Boxx pro tool case



MULTIMASTER 700 1.7 BASIC

PART NUMBER: 7229692090

KIT INCLUDES: 1 MM700 1.7, 3 accessories, 1 L-Boxx pro tool case



MULTIMASTER 700 1.7Q BASIC

PART NUMBER: 7229693090

KIT INCLUDES: 1 MM700 1.7Q, 14 accessories, 1 L-Boxx pro tool case



MULTIMASTER 700 1.7 CAULKING SET

PART NUMBER: 72297162090

KIT INCLUDES: 1 MM700 1.7, 7 accessories, 1 L-Boxx pro tool case



MULTIMASTER 700 1.7Q AUTOGLASS

PART NUMBER: 72297065090

KIT INCLUDES: 1 MM700 1.7Q, 14 accessories, 1 L-Boxx pro tool case



CAULKING CUTTER BLADES



SEGMENT BLADE
For V-cuts and for cuts in corners, 1-1/4" blade length, 2-pack

PART NUMBER:
63903132010



DIAMOND SEGMENT BLADE
Diamond-coated, for corners 3/32". For marble and cement mortar

PART NUMBER:
63903162017



CLEANING BLADE
Diamond-coated, for cleaning mortar flanks before refilling, 5-pack

PART NUMBER:
63903161030



MUSHROOM BLADE
For cutting elastic silicon or acrylic connecting joints as well as for separation of insulating glass, 5-pack

PART NUMBER:
63903128012



CUTTER BLADE
Elongated pointed blade for very deep joints, 5-pack

PART NUMBER:
63903116011
NEW!
XL VERSION (73mm)
PART NUMBER:
63903271020



STRAIGHT CUTTER BLADE
Universal blade for removal of almost all expansion joints, 5-pack

77MM PART NUMBER:
63903117015
NEW!
90MM XL VERSION
PART NUMBER:
63903270030

AUTOGLASS BLADES



U-SHAPED CUTTING BLADE
For removal glass from behind the hood. Reinforced design, serrated, 2-pack

PART NUMBER:
63903212018



L-SHAPED CUTTING BLADE - 1-1/2"
Serrated, 2-pack

PART NUMBER:
63903209014



L-SHAPED CUTTING BLADE - 3/4"
Serrated, 2-pack

PART NUMBER:
63903208010



L-SHAPED CUTTING BLADE
Serrated, 2-pack

PART NUMBER:
63903207012



U-SHAPED CUTTING BLADE
Ideal for glass removal from behind the hood. Reinforced design, 2-pack

PART NUMBER:
63903157011



U-SHAPED CUTTING BLADE
Ideal for glass removal from behind the hood. Reinforced design, 2-pack

PART NUMBER:
63903111019

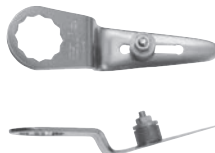

STRAIGHT CUTTING BLADE
Z-bend, with adjustable depth stop, 2-pack

PART NUMBER:
63903143013



STRAIGHT CUTTING BLADE
Suitable for removal of attached body parts.

Z-bend, serrated, 2-pack

PART NUMBER:
63903081013

CORDLESS JIGSAW

The all new F-IRON JIG 26 AS is a powerful cordless jigsaw allows you to easily make smooth curves and precise cuts in metal, wood and plastics.

NEW!

18V F-IRON JIG 26 AS CORDLESS JIGSAW

ADVANCED DUST CONTROL

Dust is kept clear of cutting area by integrated blower. Jigsaw kit comes with a dust extraction adaptor for use with FEIN or other professional shop vacuums.

CONVENIENCE

Smart LED work light with overhead shutdown function.

FAST, TOOL-FREE SAW BLADE CHANGE

The automatic saw blade lock makes it easier to change saw blades and reduces the risk of injury. Works with all universal T-shank blades.



PERFORMANCE

Compatible with the 18V AMPShare battery platform.

ADVANCED BASE SHOE DESIGN

Four adjustable miter angles with positive stops at 0°, 15°, 30° and 45° degrees in both left and right positions. Jigsaw comes with non-marring base.

F-IRON JIG 26 AS TECHNICAL SPECS

F-IRON JIG 26 AS		
Battery voltage	V	18
Battery capacity	Ah	4
Battery interface		AMPShare
Tool mount		T-shank
Stroke of blade	in	1
Tool mount		QuickIN, T-shank
Weight without battery	lbs	4.63
Part Number (Bare tool)		71360561090
Part Number (Kit)		71360562000



KIT INCLUDES: 1 F-IRON JIG 26 AS, 2 4Ah CORE 18V batteries, 1 Fast charger, 1 best-of jigsaw blade set 5-piece (63503188010), 1 zero clearance blade insert, 1 Allen key 4 mm, 1 non-marring shoe guard cover, 1 dust extraction adaptor, 1 L-Boxx pro tool case



Powered by  **BOSCH**

**AVAILABLE
APRIL 2025**

GENERAL METALWORKING BLADES

Part Number	Saw blade material	Cutting length (in)	Tooth Pitch (TPI)	Materials cut
63503166010	BIM	3"	21	1/16" - 1/8" Thick mild steel / aluminum / brass
63503167010	BIM	3"	23-18	1/16" - 1/8" Thick mild steel / aluminum / brass
63503168010	BIM	3"	12	1/64" - 3/64" metal blade
63503169010	BIM	3"	11-13	1/8" - 1/4" metal blade
63503172010	BIM	3"	10-16	1/16" - 1/8" metal blade
63503173010	BIM	4-3/8"	16-25	1/8" - 1/4" metal blade
63503174010	BIM	4-3/8"	12	1/16" - 1/8" metal blade
63503175010	HM	2-3/8"	24	Stainless steel

GENERAL WOODWORKING BLADES

Part Number	Saw blade material	Cutting length (in)	Tooth Pitch (TPI)	Materials cut
63503176010	CV	3"	6	Soft/Hard woods, OSB, plywood ideal for saws without orbital action
63503177010	CV	5-1/8"	6	Soft/Hard woods, OSB, plywood ideal for saws without orbital action
63503178010	CV	3"	6	Fast cut clean wood
63503179010	CV	3"	10	Clean wood
63503180010	CV	3"	10-18	Soft woods / plywood
63503182010	CV	3-3/4"	8-11; 10	Soft woods / plywood
63503184010	CV	3"	17	Soft woods / plywood
63503185010	BIM	3"	17	Clean hard wood
63503186010	BIM	4-3/8"	10-14	Soft woods / plywood

SPECIALTY MULTI-MATERIAL BLADES

Part Number	Saw blade material	Cutting length (in)	Tooth Pitch (TPI)	Materials cut
63503170010	BIM	3"	8	Aluminum up to 5/8", fiberglass up to 3/4", plastic up to 1-1/4"
63503171010	BIM	7"	21	Insulated panels (up to 3" thick)
63503181010	CV	3-1/2"	8	Medium to fine cuts in Soft/Hard woods, plywood, laminated particle board and plastic
63503183010	CV	3"	10	Reverse cut
63503187010	HM	3"	24	Fiberglass, plaster, cement board
63503188010	-	-	-	5-Pack Starter Set

PREMIUM VACUUMS

FEIN Dust Extractors are designed to be more efficient than traditional shop vacuums and leave your work area spotless. Coupled with FEIN's quiet, powerful operation, long hoses and power cords, and accessories for connecting a variety of power tools, you can rely on our FEIN TURBO dust extractors.

TURBO I, TURBO II & TURBO II X AC

EFFECTIVE DUST CONTROL

The 1 micron standard filtration system and a .3 micron HEPA filtration system (on select models) provides best in class particulate removal.

IMPRESSIVE SUCTION

98.4 static water lift (245 mbar) of vacuum and a 151 cfm (71 L/s) flow rate at the blower ensures powerful suction and fast dust extraction.



SENSIBLE STORAGE

Rimmed storage features cable hose hooks.

AUTOSTART OUTLET

Quickly starts when attached tool is switched on and runs briefly after shut down to clear hose of remaining dust.

SUPERIOR MOBILITY

Easy to maneuver with large, 360 degree wheels.

TURBO ACCESSORIES

Non-woven filter bag
5 pack



Part Number
Turbo I 31345061010

Non-woven filter bag
5 pack



Part Number
Turbo II 31345062010

Non-woven filter bag, premium
5 pack



Part Number
Turbo II 31345251010

HEPA filter bag
3 pack



Part Number
31345130010

Cellulose flat pleated filter



Part Number
31345012010

Flat pleated filter PES



Part Number
31345059010

HEPA flat pleated filter



Part Number
31345060010

HEPA flat pleated filter - TURBO X AC



Part Number
31345274010

Anti-static suction hose
13 ft length.



Part Number
1-3/8 in dia 31345120010

Tool coupling with suction control



Part Number
1-3/8 in dia 31345300010

Accessory set for FEIN vacuum cleaners

Consisting of: 2 metal suction tubes, 1 combination tool with interchangeable inserts, 1 crevice nozzle, 1 dusting brush, 1 elbow



BEST VALUE

Part Number
31345071020

Step adapter



Part Number
31345079010

Dusting brush



Part Number
31345076010

Upholstery nozzle



Part Number
31345075010

Crevice nozzle



Part Number
31345074010

ALL VACUUMS FEATURE

- + 1,100 Watt (9 Amp) power
- + 151 CFM Air volume
- + 98.4 inches of static water lift
- + 13 ft long vacuum hose
- + Quiet operation (66 dB)
- + Extra long 19 ft power cord
- + Autostart outlet with power-on delay



TURBO I Wet/Dry Dust Extractor

- PART NUMBER:** 92035236090
- + 5.8 gallon capacity
 - + 1 micron filtration



NEW!

TURBO I HEPA PRO SET Wet/Dry Dust Extractor

- PART NUMBER:** 92037060990
- + 5.8 gallon capacity
 - + .3 micron filtration
 - + HEPA certified
 - + Includes hoses & tool attachments



TURBO II Wet/Dry Dust Extractor

- PART NUMBER:** 92036236090
- + 8.5 gallon capacity
 - + 1 micron filtration



NEW!

TURBO II HEPA PRO SET Wet/Dry Dust Extractor

- PART NUMBER:** 92036060990
- + 8.5 gallon capacity
 - + .3 micron filtration
 - + HEPA certified
 - + Includes hoses & tool attachments



NEW!
NOW INCLUDES
ANTI-STATIC HOSE!

TURBO II X AC HEPA PRO SET Wet/Dry Dust Extractor

- PART NUMBER:** 92030070990
- + 9.2 gallon capacity
 - + .3 micron filtration
 - + HEPA certified
 - + Autoclean function
 - + Variable speed
 - + Includes hoses & tool attachments

BATTERIES & CHARGERS

AMPShare - Powered by Bosch is a power source that works across expert brands, allowing various applications to be powered by one battery system.

AMP SHARE BATTERIES & CHARGERS



CORE 18V 2.0Ah A
PART NUMBER:
92604344030



CORE 18V AS 4.0 Ah
PART NUMBER:
92604341030



CORE 18V AS 8.0 Ah
PART NUMBER:
92604342030



CORE 18V AS 12.0 Ah
PART NUMBER:
92604343030



CORE 18V AS STARTER SET 2.0 Ah
PART NUMBER: 92604244090



CORE 18V AS STARTER SET 4.0 Ah
PART NUMBER: 92604228090



CORE 18V AS STARTER SET 8.0 Ah
PART NUMBER: 92604229090



CORE 18V AS STARTER SET 12.0 Ah
PART NUMBER: 92604241090



14.4-18V AS Fast Charger
PART NUMBER: 92604334010
Best for 2.0Ah & 4.0Ah batteries



18V AS Turbo Charger
PART NUMBER: 92604338010
Best for 4.0Ah, 8.0Ah & 12Ah batteries

AMP SHARE ADVANTAGES AT A GLANCE

EXPANDED COMPATIBILITY

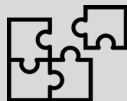

AMPShare™ batteries and chargers are compatible with Bosch 18V power tools and with cordless products part of the multi-brand AMPShare™ Alliance.

19

LEADING BATTERY & CHARGER TECHNOLOGY



Within AMPShare™, batteries with CORE18V® technology offer a high-performance record, heat management technology, and an optimal power-to-weight ratio to power the toughest work. To keep power-ready, AMPShare™ offers both fast and faster charging solutions.

PROFESSIONAL EXPERTISE



All members of the AMPShare™ Alliance are leading expert brands in their field committed to meeting the highest demands of trade and industry.

COMPLETE FLEXIBILITY

Use the same battery for the new cordless MULTIMASTER AS with AMPSHare interface and for all 18V cordless devices with AMPSHare or Bosch Professional 18V battery interface.

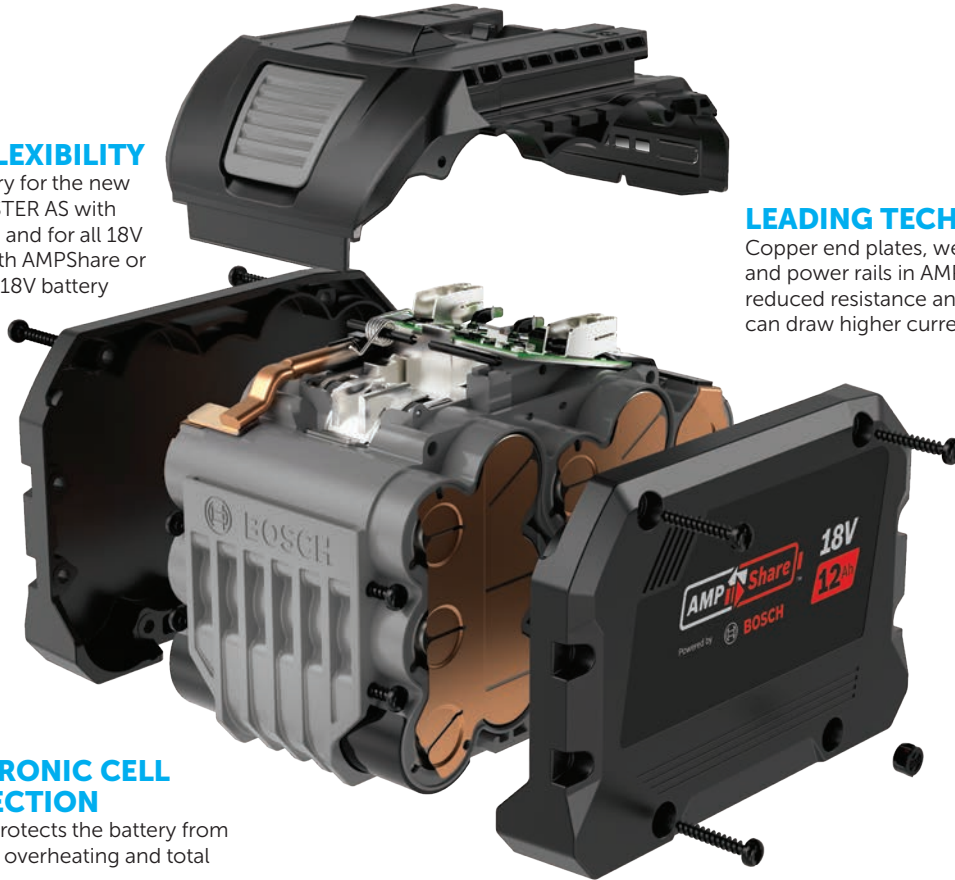

LEADING TECHNOLOGY

Copper end plates, welded cell connectors and power rails in AMPShare batteries provide reduced resistance and greater efficiency, so tools can draw higher currents over a longer time.

ELECTRONIC CELL PROTECTION

Reliably protects the battery from overload, overheating and total discharge.

COOLPACK 2.0 TECHNOLOGY

4 Ah, 8Ah and 12Ah Batteries are equipped with CoolPack technology that delivers longer life for batteries with better heat management to protect the cells from damage.

Each cell is housed in its own heat sync with no air gaps between cells for better heat dissipation. More surface area on the shell provides better heat transfer to the outer surface.

FASTER THAN EVER CHARGING

The new AMPShare Fast Charger helps avoid downtime by charging batteries in a fraction of the time compared to conventional battery and chargers. The AS Fast Charger charges 4Ah batteries to 80% in 32 minutes and 2Ah batteries in just 15 minutes which means you don't have to slow down just because your battery does.

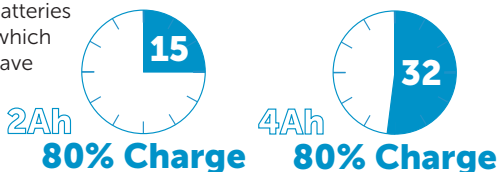

SAVINGS WITH ONE SYSTEM



AMPShare™ alleviates the need to invest in multiple battery platforms by offering compatibility with different brands and their cordless tools.

EASIER BATTERY MANAGEMENT

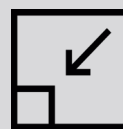

AMPShare™ reduces the clutter and complexity of managing and working with multiple battery and charger solutions.

A GROWING NETWORK



AMPShare™ batteries today will be compatible with even more tools from even more brands in the future.

INTRODUCING THE NEW ULTIMATE 4-SPEED DRILL DRIVERS FROM FEIN



- + MADE IN GERMANY
- + ALL METAL GEARBOX
- + 11 APPLICATIONS 1 TOOL
- + 18V AMPSHARE BATTERY PLATFORM
- + 4 SPEED RANGES
- + FEIN POWERDRIVE BRUSHLESS MOTOR

VERSATILITY MEETS FUNCTION... MEET THE **QUICKIN SYSTEM FROM FEIN**

11 QuickIN applications, one drill, endless possibilities. With the QuickIN System from FEIN, you can quickly and easily change between applications to save time and stay on track.

GENERAL CONSTRUCTION

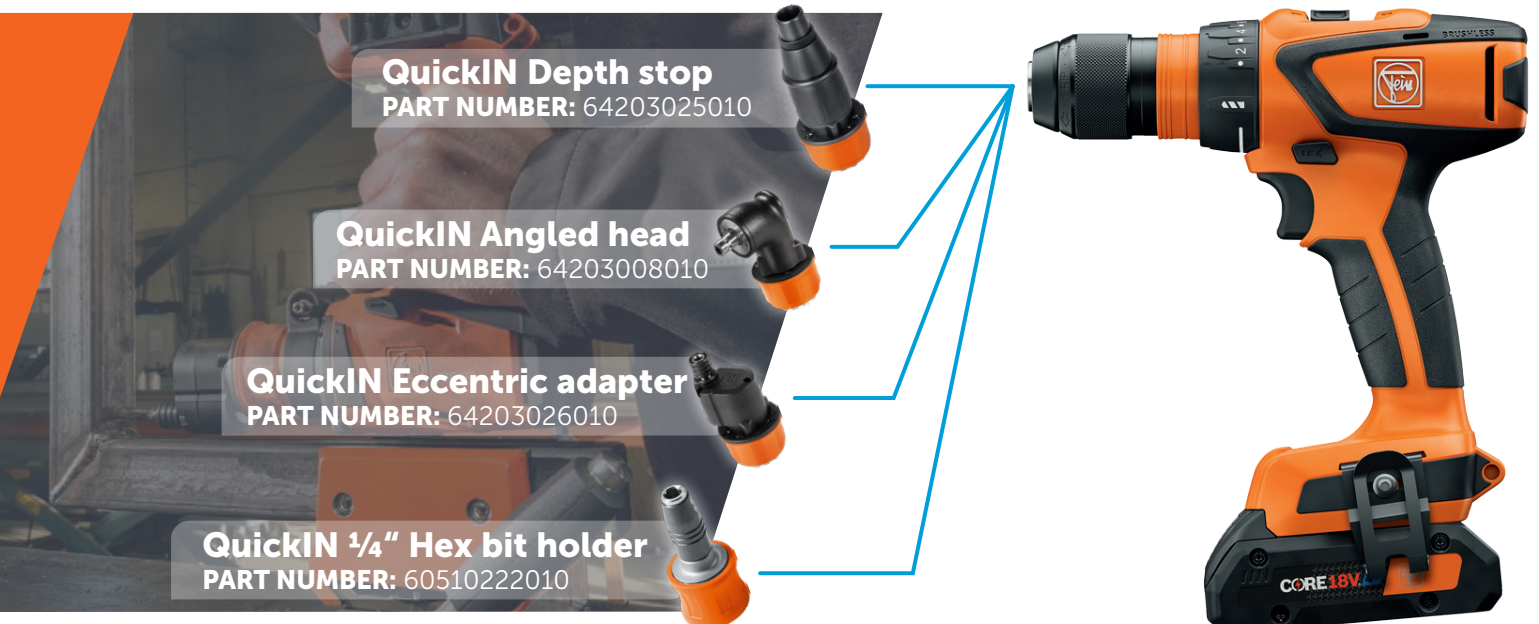



ASCM 18-4 QM(P) HIGH TORQUE

FULL INFO ON PAGE 23

- + 2 Models - With & without hammer function
- + Max torque - 1,150 in/lb
- + Telescoping handle



ASCM 18 QSW GENERAL CONSTRUCTION

FULL INFO ON PAGE 25

- + 1 Model available
- + Max torque - 354 in/lb

METAL WORKING

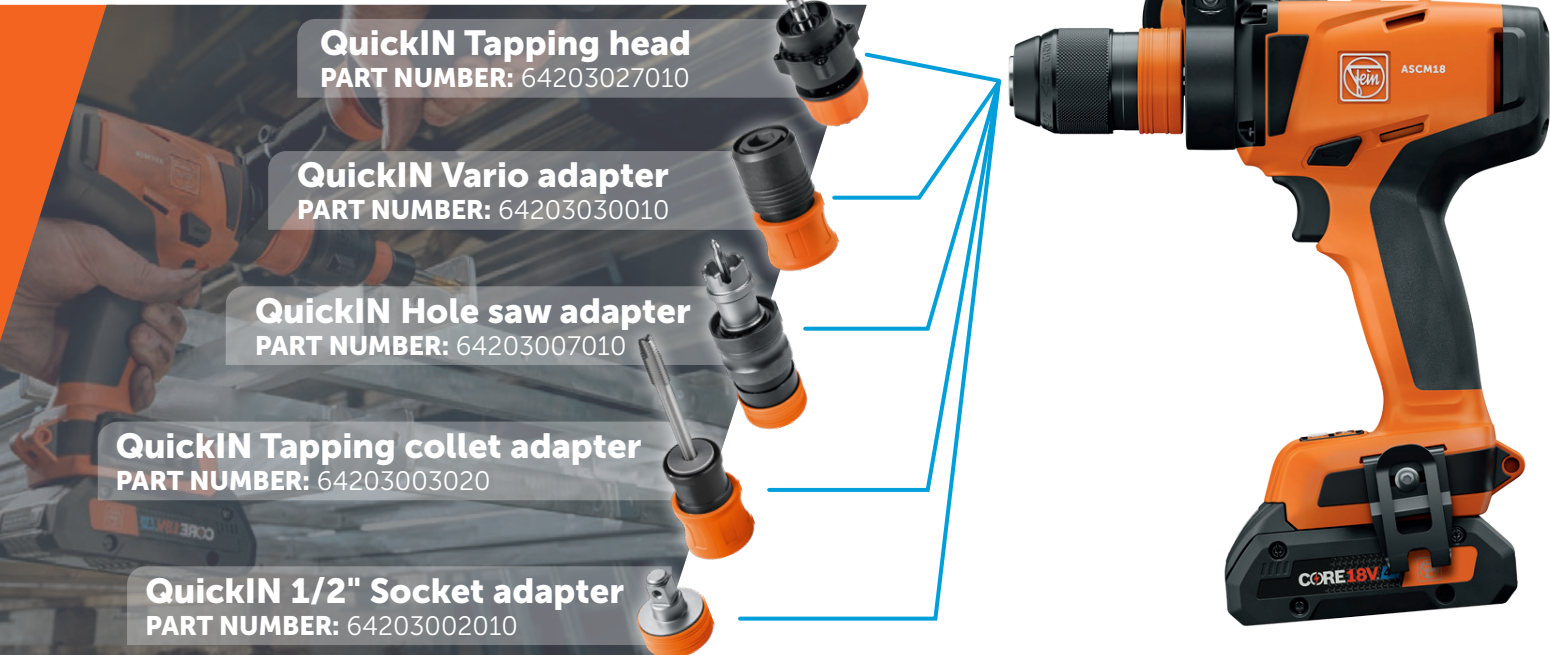

QuickIN Tapping head
PART NUMBER: 64203027010

QuickIN Vario adapter
PART NUMBER: 64203030010

QuickIN Hole saw adapter
PART NUMBER: 64203007010

QuickIN Tapping collet adapter
PART NUMBER: 64203003020

QuickIN 1/2" Socket adapter
PART NUMBER: 64203002010



QUICKIN ACCESSORIES SET

PART NUMBER: 64203033010

KIT INCLUDES: 1 QuickIN Eccentric head, 1 QuickIN Tapping head, 1 QuickIN Tapping adapter (w/o collet), 1 QuickIN Angled head, 1 QuickIN Hole saw adapter w/centering bit, 1 QuickIN socket adapter, 1 QuickIN bitholder, 1 QuickIN VARIO adapter, 1 i-BOXX 72

CORDLESS DRILL/DRIVING

The performance and reliability needed for demanding metalworking jobs. Powerful AMPShare 18V drills and drill drivers from FEIN meet the rigorous needs of your job site.

NEW!

18V ASCM 4-SPEED HIGH TORQUE DRILL DRIVERS



USER PROTECTION

Restart protection, electronic overload protection and brake.

MADE IN GERMANY

MORE CONTROL

Extendible extra handle for improved leverage and grip.

ADAPTABLE

The QuickIN heads can be changed in a matter of seconds and without the need for tools when users switch between applications - All drill/drivers come standard with a 3-jaw chuck.



POWERFUL

4-speed solid metal gearbox. With speeds of up to 4000 rpm for optimum cutting speeds in metal.



OPERATOR PANEL FUNCTIONS

- + Drilling
- + Screwdriving
- + Fastening with precision depth control
- + Kickback monitoring
- + Work area LED
- + LED brightness adjustment

AVAILABLE BARE TOOLS

18V ASCM HIGH TORQUE 4-SPEED DRILL DRIVERS



MADE IN GERMANY

ASCM 18-4 QMP AS

Battery voltage	V	18
Battery platform		AMPShare
Motor		brushless
Gearbox		4-Speed
No load speed	RPM	430 / 850 / 2,000 / 4,000
Impacts per minute (hammer function)	IPM	6,450 / 12,750 / 30,000 / 60,000
Max. torque		1,150 in/lb
Tool mount		QuickIN
Weight without battery	lbs	3.08
Part Number (Bare tool)		71161661090

ASCM 18-4 QMP AS SELECT

18V 4-speed cordless drill/driver **w/hammer function** (bare tool)

PART NUMBER: 71161661090

KIT INCLUDES: 1 ASCM 18-4 QMP AS, 1 belt clip, 1 telescopic handle, 1 QuickIN drill chuck, 1 magnetic bit holder, 1 L-Boxx pro tool case



MADE IN GERMANY

ASCM 18-4 QM AS

Battery voltage	V	18
Battery platform		AMPShare
Motor		brushless
Gearbox		4-Speed
No load speed	RPM	430 / 850 / 2,000 / 4,000
Max. torque		1,150 in/lb
Tool mount		QuickIN
Weight without battery	lbs	3.08
Part Number (Bare tool)		71161561090

ASCM 18-4 QM AS SELECT

18V 4-speed cordless drill/driver (bare tool)

PART NUMBER: 71161561090

KIT INCLUDES: 1 ASCM 18-4 QM AS, 1 belt clip, 1 telescopic handle, 1 QuickIN drill chuck, 1 magnetic bit holder, 1 L-Boxx pro tool case

AVAILABLE BARE TOOLS

The performance and reliability needed for demanding metalworking jobs. Powerful AMPShare 18V drills and drill drivers from FEIN meet the rigorous needs of your job site.



MADE IN GERMANY		ASCM 18 QSW AS	
Battery voltage	V	18	
Battery platform	AMPShare		
Motor	brushless		
Gearbox	4-Speed		
No load speed	RPM	400 / 700 / 1,400 / 2,500	
Max. torque	354 in/lb		
Tool mount	QuickIN		
Weight without battery	lbs	3.08	
Part Number (Bare tool)	71161461090		

ASCM 18 QSW AS SELECT

18V 4-speed General Construction Cordless Drill/Driver (bare tool)

SELECT PART NUMBER: 71161461090

KIT INCLUDES: 1 ASCM 18 QSW AS, 1 QuickIN drill chuck, 1 belt clip, 1 magnetic bit holder, 1 L-Boxx pro tool case



MADE IN GERMANY		ASCD 18-200 W4 AS	
Battery voltage	V	18	
Battery platform	AMPShare		
Motor	brushless		
Gearbox	-		
No load speed	RPM	0 - 1,500	
Impacts per minute	IPM	0 - 3,000	
Max. torque	1,858 in/lb		
Tool mount	1/4" hexagon		
Weight without battery	lbs	2.64	
Part Number (Bare tool)	71151161090		

ASCD 18-200 W4 AS SELECT

18V 1/4" Hex Cordless Impact Driver (bare tool)

SELECT PART NUMBER: 71151161090

KIT INCLUDES: 1 ASCD 18-200 W4 AS, 1 magnetic bit holder, 1 belt clip, 1 L-Boxx pro tool case



MADE IN GERMANY		ASCD 18-300 W2 AS	
Battery voltage	V		18
Battery platform			AMPShare
Motor			brushless
Gearbox			-
No load speed	RPM		0 - 1,700
Impacts per minute	IPM		0 - 3,400
Max. torque			214 ft/lb
Tool mount			1/2" square
Weight without battery	lbs		2.20
Part Number (Bare tool)			71151061090

ASCD 18-300 W2 AS SELECT

18V Cordless Impact Wrench - 1/2" Square Drive (bare tool)

SELECT PART NUMBER: 71151061090

KIT INCLUDES: 1 ASCD 18-300 W2 AS, 1 belt clip, 1 L-Boxx pro tool case



		ASCD 18-1000 W34 AS	
Battery voltage	V		18
Battery platform			AMPShare
Motor			brushless
Gearbox			-
No load speed	RPM		0 - 1,800
Impacts per minute	IPM		0 - 2,200
Max. torque			775 ft/lb
Tool mount			3/4" square
Weight without battery	lbs		6.83
Part Number (Bare tool)			71151261090

ASCD 18-1000 W34 AS SELECT

18V Cordless Impact Wrench - 3/4" Square Drive (bare tool)

SELECT PART NUMBER: 71151261090

KIT INCLUDES: 1 ASCD 18-1000 W34 AS, 1 belt clip, 1 L-Boxx pro tool case

AVAILABLE KITS

The performance and reliability needed for demanding metalworking jobs. Powerful AMPShare 18V drills and drill drivers from FEIN meet the rigorous needs of your job site.



MADE IN GERMANY

ASCM 18-4 QMP AS QUICKIN START SET

Battery voltage	V	18
Battery platform		AMPShare
Motor		brushless
Gearbox		4-Speed
No load speed	RPM	430 / 850 / 2,000 / 4,000
Impacts per minute (hammer function)	IPM	6,450 / 12,750 / 30,000 / 60,000
Max. torque		1,150 in/lb
Tool mount		QuickIN
Weight without battery	lbs	3.08
Part Number		71161562090

ASCM 18-4 QMP AS QUICKIN START SET

4-speed cordless drill/driver set **w/hammer** function

PART NUMBER: 71161562090

KIT INCLUDES: 1 ASCM 18-4 QMP AS, 1 4Ah CORE 18V batteries, 1 Fast charger, 1 belt clip, 1 telescopic handle, 1 QuickIN drill chuck, 1 magnetic bit holder, 8-piece bit set, 1 L-BOXX

MADE IN GERMANY

ASCM 18-4 QMP AS QUICKIN TOP SET

Battery voltage	V	18
Battery platform		AMPShare
Motor		brushless
Gearbox		4-Speed
No load speed	RPM	430 / 850 / 2,000 / 4,000
Impacts per minute (hammer function)	IPM	6,450 / 12,750 / 30,000 / 60,000
Max. torque		1,150 in/lb
Tool mount		QuickIN
Weight without battery	lbs	3.08
Part Number		71161565090



ASCM 18-4 QMP AS QUICKIN TOP SET

4-speed cordless drill/driver set **w/hammer** function

PART NUMBER: 71161565090

KIT INCLUDES: 1 ASCM 18-4 QMP AS, 2 4Ah CORE 18V batteries, 1 Fast charger, 1 QuickIN Eccentric head, 1 QuickIN Tapping head, 1 QuickIN Tapping adapter, 1 QuickIN Angled head, 1 QuickIN Hole saw adapter w/centering bit, 1 QuickIN socket adapter, 1 QuickIN bitholder, 1 QuickIN VARIO adapter, 1 belt clip, 1 telescopic handle, 1 QuickIN drill chuck, 1 magnetic bit holder, 1 L-BOXX, 1 i-BOXX 72 with rack

QUICKIN METALWORKING ACCESSORIES

All FEIN cutters feature high performance carbide and optimal cutting geometry for precise, clean and efficient hole cutting.



ANNULAR CUTTERS - 3/4" DEPTH OF CUT

Part Number	Description
63130200010	9/16" x 3/4"
63130201010	5/8" x 3/4"
63130202010	11/16" x 3/4"
63130203010	3/4" x 3/4"
63130204010	13/16" x 3/4"
63130205010	7/8" x 3/4"
63130206010	15/16" x 3/4"
63130207010	1" x 3/4"
63130208010	1-1/16" x 3/4"
63130209010	1-1/8" x 3/4"
63130210010	1-3/16" x 3/4"



PIPE & TUBE CUTTERS - 5/32" DEPTH OF CUT

Part Number	Description
63131605010	7/8" x 5/32"
63131606010	15/16" x 5/32"
63131608010	1-1/16" x 5/32"
63131609010	1-1/8" x 5/32"
63131610010	1-3/16" x 5/32"
63131611010	1-1/4" x 5/32"
63131612010	1-5/16" x 5/32"
63131613010	1-3/8" x 5/32"
63131614010	1-7/16" x 5/32"
63131615010	1-1/2" x 5/32"
63131616010	1-9/16" x 5/32"
63131617010	1-5/8" x 5/32"
63131618010	1-11/16" x 5/32"
63131619010	1-3/4" x 5/32"
63131620010	1-13/16" x 5/32"
63131621010	1-7/8" x 5/32"
63131622010	1-15/16" x 5/32"
63131623010	2" x 5/32"
63131624010	2-1/16" x 5/32"
63131625010	2-1/8" x 5/32"

POLISHERS

With an impressive lineup of metalworking tools, its no wonder the pros turn to FEIN when they need quality, durable grinders that can stand the test of time.



RS 17-70 E PIPE POLISHER SET

- + Variable speed control for professional surface treatment on vehicles and boats.
- + Universally useable as a full-featured grinder, finisher and polisher.
- + Left and right handed operation.
- + Carbon brushes with automatic switch-off function.

		RS 17-70 E
Power consumption	W	1,700
Power output	W	1,000
No load speed	RPM	2,700 - 8,500
Belt speed		30 - 89 ft/sec
Pipes up to Ø		1/4 - 3-1/4"
Belt dimension		3/4 - 1-1/2"
Cable with plug		13.1 ft
Weight	lbs	9.48
Part Number		72227561090

PRICE INCLUDES: 1 RS 17-70 E, 20 sanding belts 13/16 x 32-1/16 in (10 each of grits 120 and 180), 20 sanding belts 1-9/16 x 32-1/16 in (10 each of grits 120 and 180), 5 fleece belts 13/16 x 32-1/16 in, very fine grit 280, 1 tool case



WPO 14-15 E POLISHER SET

- + Variable speed control for professional surface treatment on vehicles and boats.
- + Converts to a rotary sander with extraction hood and backing pad.
- + Left and right handed operation.
- + Carbon brushes with automatic switch-off function.

		WPO 14-15 E
Power consumption	W	1,200
Power output	W	750
No load speed	RPM	500 - 1,500
Polishing disc Ø		9 in.
Mounting thread		M 14
Cable with plug		13.1 ft
Weight	lbs	5.51
Part Number		72214850070

PRICE INCLUDES: 1 WPO 14-15 E, 1 handle bracket (rotatable), 1 hand guard, 1 arbor, 1 fleece wheel with corrugated folds, 1 backing pad with H&L (4-1/2 in dia. 5/8 in-11), 10 sanding fleece with H&L (4-1/2 in dia. fine), 1 gum wheel (4 x 4 in dia., 60 grit), 1 fleece wheel (4 x 4 in dia., 180 grit), 2 wrenches, 1 anti-vibration handle, 1 tool case



WPO 14-25 E POLISHER SET

- + Variable speed control for professional surface treatment on vehicles and boats.
- + Converts to a rotary sander with extraction hood and backing pad.
- + Carbon brushes with automatic switch-off function.

WPO 14-25 E		
Power consumption	W	1,200
Power output	W	750
No load speed	RPM	900 - 2,500
Backing pad		9 in.
Polishing disc Ø		9 in.
Mounting thread		M 14
Cable with plug		13.1 ft
Weight	lbs	5.51
Part Number		72214950080

PRICE INCLUDES: 1 WPO 14-25 E, 1 handle bracket (rotatable), 1 hand guard, 1 arbor, 1 fleece wheel with corrugated folds, 1 backing pad with H&L (4-1/2 in dia. 5/8 in-11), 10 sanding fleece with H&L (4-1/2 in dia. fine), 1 gum wheel (4 x 4 in dia., 60 grit), 1 fleece wheel (4 x 4 in dia., 180 grit), 2 wrenches, 1 anti-vibration handle, 1 tool case

POLISHER ACCESSORIES

																							
2" Work Arbor PART NUMBER: 63803072020	4" Work Arbor PART NUMBER: 63803068020	Protect Suction Hood PART NUMBER: 31810264010	Elastic Disc PART NUMBER: 63806187010	6" Pad PART NUMBER: 63806188010	Stainless Steel Satin Flat Kit PART NUMBER: 63721050020																		
																							
Gum Wheel 60 grit 4" PART NUMBER: 63721006012	Gum Wheel 180 grit 4" PART NUMBER: 63721007016	Gum Wheel 60 grit 2" PART NUMBER: 63721054010	Gum Wheel 180 grit 2" PART NUMBER: 63721055010	Fleece Wheel K280 PART NUMBER: 63721010010	Sinus Fleece Wheel 180 grit 4" PART NUMBER: 63721051010	Sinus Fleece Wheel 180 grit PART NUMBER: 63721056010																	
																							
Fleece Wheel K100 PART NUMBER: 63721008014	Fleece Wheel K180 PART NUMBER: 63721009018	Expansion Roller 4" PART NUMBER: 63806192010	Polishing Sponge PART NUMBER: 63723034010	Lambs Wool Dome Shape PART NUMBER: 63723035010	Felt Fleece Wheels PART NUMBER: Soft - 63721057010 Medium - 63721058010																		
Pyramix Sleeves - 5 Pack		Adrasive Sleeves - 5 Pack		16 pc. Stainless Steel Grinding Set Flat Finish																			
	<table border="1"> <thead> <tr> <th>Grit</th> <th>Part Number</th> </tr> </thead> <tbody> <tr> <td>280</td> <td>63714145010</td> </tr> <tr> <td>400</td> <td>63714146101</td> </tr> <tr> <td>600</td> <td>63714147010</td> </tr> <tr> <td>1,400</td> <td>63714148010</td> </tr> </tbody> </table>	Grit	Part Number	280	63714145010	400	63714146101	600	63714147010	1,400	63714148010		<table border="1"> <thead> <tr> <th>Grit</th> <th>Part Number</th> </tr> </thead> <tbody> <tr> <td>60</td> <td>63714132010</td> </tr> <tr> <td>80</td> <td>63714133010</td> </tr> <tr> <td>120</td> <td>63714134010</td> </tr> </tbody> </table>	Grit	Part Number	60	63714132010	80	63714133010	120	63714134010		PART NUMBER: 63806192020
Grit	Part Number																						
280	63714145010																						
400	63714146101																						
600	63714147010																						
1,400	63714148010																						
Grit	Part Number																						
60	63714132010																						
80	63714133010																						
120	63714134010																						

GRINDING

With an impressive lineup of metalworking tools, its no wonder the pros turn to FEIN when they need quality, durable grinders that can stand the test of time.

WSG 7 SERIES - 7 AMP

- + Compact ergonomic grip
- + Paddle switch with dead-man function and slide switch models available
- + Solid metal drive head rotates in 90° increments, no plastic components



WSG 7-115
4-1/2" slide switch grinder
Speed: 12,500 RPM
PART NUMBER:
72219760120



WSG 7-115 PT
4-1/2" paddle switch grinder
Speed: 12,500 RPM
PART NUMBER:
72223160120

CG 10 SERIES - 10 AMP

- + Dust protection grille
- + Paddle switch with dead-man function
- + Solid metal drive head rotates in 90° increments, no plastic components
- + 4-1/2" and 5" models



CG 10-115PDEV
4-1/2" paddle switch grinder
Variable speed:
2,700 - 10,500 RPM
PART NUMBER:
72225960120



CG10-115PDE
4-1/2" paddle switch grinder
Speed: 10,500 RPM
PART NUMBER:
72226060120



CG10-125PDE
5" paddle switch grinder
Speed: 10,500 RPM
PART NUMBER:
72226160120

CG 13 SERIES - 13 AMP

- + Dust protection grille
- + Paddle switch with dead-man function and slide switch models available
- + Solid metal drive head rotates in 90° increments, no plastic components
- + Robust guard system & antivibration handle
- + 5" and 6" models



CG13-150 SS
6" slide switch grinder
Speed: 9,300 RPM
PART NUMBER:
72228361090



CG13-125PDE
5" paddle switch grinder
Speed: 11,500 RPM
PART NUMBER:
72226460120



CG13-150PDEV
6" paddle switch grinder
Variable speed:
2,500-9,500 RPM
PART NUMBER:
72226260120



CG13-150PDE
6" paddle switch grinder
Speed: 9,500 RPM
PART NUMBER:
72226360120

A RADICALLY IMPROVED CONCEPT.

NEW

CG 15 – The first of its class to include a brushless FEIN PowerDrive fully enclosed motor. Available with paddle switch or slide switch.

MADE IN GERMANY

LIGHT BUT POWERFUL

Best weight/performance ratio at 4.8lbs. and 1,050W output power. Significantly higher efficiency than an angle grinder with 1,700W rated input.

EXTREME DURABILITY

Sealed electronic components protect the unit from damaging grinding dust. Overload protection is built in to lead to fewer breakdowns and longer tool life.

READY FOR ANY APPLICATION

The infinitely variable electronic speed - ideal for a wide range of abrasives and applications.

NEW! ADVANCED MOTOR TECHNOLOGY

Completely enclosed brushless FEIN PowerDrive motor with optimized air flow boosts efficiency and power delivery for all applications.



WORK SAFELY

All CG-15 grinders feature soft start, kickback and jam monitoring with a **rapid (<2 sec) motor brake** actuation. Paddle switch models also feature a lanyard eyelet for fall protection.

CG 15 SLIDE SWITCH SERIES - 13 AMP

- + Brushless FEIN PowerDrive Motor
- + Slide switch models
- + Solid metal drive head rotates in 90° increments, no plastic components
- + Anti-vibration handle



CG 15-125 BL 5" slide switch grinder

Variable speed:
3,800 - 9,000 RPM

PART NUMBER:
72226760120



CG 15-125 BL INOX 5" slide switch grinder

Variable speed:
2,800 - 7,000 RPM

PART NUMBER:
72228660120



CG 15-150 BL 6" slide switch grinder

Variable speed:
2,800 - 7,000 RPM

PART NUMBER:
72227860120

CG 15 PADDLE SWITCH SERIES - 13 AMP

- + Brushless FEIN PowerDrive Motor
- + Paddle switch models
- + Solid metal drive head rotates in 90° increments, no plastic components
- + Anti-vibration handle
- + Lanyard hook included



CG 15-125 BLP 5" paddle switch grinder

Variable speed:
3,800 - 9,000 RPM

PART NUMBER:
72227660120



CG 15-125 BLP INOX 5" paddle switch grinder

Variable speed:
2,800 - 7,000 RPM

PART NUMBER:
72228560120



CG 15-150 BLP 6" paddle switch grinder

Variable speed:
2,800 - 7,000 RPM

PART NUMBER:
72227760120

CORDLESS ANGLE GRINDERS

Durability and portability make the NEW AMPShare cordless angle grinders with FEIN's powerful, fully encapsulated motors and variable speed control the perfect tools for any application.

MADE IN GERMANY

CCG-18 BL SERIES - 18V SLIDE SWITCH

- + Encapsulated, dust-proof and maintenance free, variable speed brushless motors
- + Solid metal drive head rotates in 90° increments
- + Anti-vibration, soft start, restart protection, overload protection and safety brake
- + LED light for clear vision of workpiece
- + Power equivalent to 1200W corded tool (10A)



CCG 18-125 BL AS SELECT
5" slide switch grinder
Variable speed: 2,500 - 8,500 RPM
PART NUMBER: 71220260120



CCG 18-125 BL AS
5" slide switch grinder
Variable speed: 2,500 - 8,500 RPM

PART NUMBER: 71220262120
Includes: 1 CCG 18-125 BL AS, 1 guard, 1 tool-free quick-action clamping nut, 1 anti-vibration handle, 1 wrench, 1 CORE 18 V 8.0 Ah battery pack, 1 GAL18 V-160 AS rapid charger, 1 nylon tool bag

CCG-18 BLPD SERIES - 18V PADDLE SWITCH

- + Encapsulated, dust-proof and maintenance free, variable speed brushless motors
- + Paddle switch with dead-man function
- + Solid metal drive head rotates in 90° increments
- + Anti-vibration, soft start, restart protection, overload protection and safety brake
- + LED light for clear vision of workpiece
- + Power equivalent to 1200W corded tool (10A)



CCG 18-125 BLPD AS SELECT
5" paddle switch grinder
Variable speed: 2,500 - 8,500 RPM
PART NUMBER: 71220460120



CCG 18-125 BLPD AS
5" paddle switch grinder
Variable speed: 2,500 - 8,500 RPM

PART NUMBER: 71220462120
Includes: 1 CCG 18-125 BL PD AS, 1 guard, 1 tool-free quick-action clamping nut, 1 anti-vibration handle, 1 wrench, 1 CORE 18 V 8.0 Ah battery pack, 1 GAL18 V-160 AS rapid charger, 1 nylon tool bag

AGSZ 18 CORDLESS DIE GRINDERS - 18V

- + Extended reach grinding
- + Variable speed
- + Motor and electronics protected against metal dust
- + Ideal for stainless and structural steel



MADE IN GERMANY



AGSZ 18-280 BL AS SELECT
Variable speed: 9,000 - 28,000 RPM
PART NUMBER: 71230461090



AGSZ 18-280 LBL AS SELECT
Variable speed: 9,000 - 28,000 RPM
PART NUMBER: 71230561090



AGSZ 18-90 LBL AS SELECT
Variable speed: 2,900 - 9,000 RPM
PART NUMBER: 71230661090



DIE GRINDERS

Difficult-to-reach areas are now easily accessible with FEIN's die grinders. Each die grinder features FEIN's fully encapsulated and brushless PowerDrive motor. With its variable speed control, RPM's can be adjusted to specific applications.

MADE IN GERMANY

GSZ 8 **DIE GRINDER - 6.25 AMP**

- + Fits in difficult-to-reach spots
- + Motor and electronics protected against metal dust
- + Ideal for stainless and structural steel



GSZ 8-280 P
Speed: 28,000 RPM
PART NUMBER: 72231660090



GSZ 8-280 PE
Variable speed: 8,500 - 28,000 RPM
PART NUMBER: 72231760090

GSZ 4 LONG REACH **DIE GRINDER - 3 AMP**

- + Extended reach grinding
- + Variable speed
- + Motor and electronics protected against metal dust
- + Ideal for stainless and structural steel



GSZ 4-280 EL
Variable speed: 13,000 - 28,000 RPM
PART NUMBER: 72232460090



GSZ 4-90 EL
Variable speed: 3,500 - 8,500 RPM
PART NUMBER: 72232560090

GSZ 8 LONG REACH **DIE GRINDER - 6.25 AMP**

- + Extended reach grinding
- + Variable speed
- + Motor and electronics protected against metal dust
- + Ideal for stainless and structural steel



GSZ 8-280 PEL
Variable speed: 8,500 - 28,000 RPM
PART NUMBER: 72231960090



GSZ 8-90 PEL
Variable speed: 2,500 - 9,000 RPM
PART NUMBER: 72232060090

GSZ 11 LONG REACH RAT TAIL **DIE GRINDER - 8.5 AMP**

- + Extended reach grinding
- + Variable speed
- + Motor and electronics protected against metal dust
- + Ideal for stainless and structural steel
- + Rat tail grip provides an ergonomic fit for better control and comfort



GSZ 11-320 PERL
Variable speed: 9,500 - 32,500 RPM
PART NUMBER: 72232260090



GSZ 11-90 PERL
Variable speed: 2,900 - 9,900 RPM
PART NUMBER: 72232360090

BEVELERS

FEIN corded and cordless Bevelers are an accurate and precise way to make bevels and radii on flat materials, sheet metal and containers, for inner and outer edges, contours, and rounding holes. A compact and lightweight design makes them perfect for tight spaces and fatigue-free work.

AKFH 18-5T AS CORDLESS BEVELER

KIT PART NUMBER: 71380562090

SELECT PART NUMBER: 71380360090

DURABLE

Brushless FEIN PowerDrive motor. Completely encapsulated and maintenance-free.

POWERFUL

CORE 18 V Li-ion battery with Highpower cells, charge indicator and electronic cell protection (ECP), protecting batteries against overloading, overheating and deep discharge.

SAFETY

With soft start, restart protection, blockage monitoring and electronic overload protection.

FUNCTIONAL

Produce chamfers and radii on inner and outer edges of flat materials.



		AKFH 18-5T AS
BATTERY VOLTAGE	V	18
BATTERY PLATFORM		AMPShare
NO LOAD SPEED	RPM	2,400 - 7,500
BEVEL LENGTH MAX @45°	IN (MM)	3/16 (5)
BEVEL HEIGHT MAX @45°	IN (MM)	1/8 (3.5)
BEVEL ANGLE		45°
RADIUS	IN (MM)	1/16 / 1/8 (1.2 / 2.5)
MILLING HEAD CONFIGURATION		3 x SX-Plate
SUPPORT PLATE DIAMETER	IN (MM)	3 7/8 (98)
WEIGHT W/O BATTERY	LBS (KG)	6.6 (3.0)

KIT PRICE INCLUDES: 1 AKFH 18-5T AS, 1 8Ah CORE 18V battery, 1 Fast charger, 3 Clamping screw, 1 Copper paste, 1 Allen key 4 mm, 1 Torx screw driver TX15, 1 Beveler head, 1 Ø 21.69 mm guide roller for 45° bevel and 2.5 mm radius, 45° mild steel inserts, 1 L-BOXX



KFH 17-8 RT BEVELER**

PART NUMBER: 72381761090

SAFETY

With soft start, restart protection, blockage monitoring and electronic overload protection.

HIGH-PERFORMANCE

High removal rate of material with low effort.



FEIN ERGOGRIP

Ergonomic handle design. For efficient, that reduces fatigue. Maximum hold and control, even when wearing welders' gloves.

BOOSTER TECHNOLOGY

Booster Technology offers significantly reduced vibration and chatter for improved performance.

KFH 17-8 RT		
INPUT POWER	W	1,500
POWER OUTPUT	W	835
NO LOAD SPEED	RPM	2,300 - 7,500
BEVEL LENGTH MAX @45°	IN (MM)	5/16 (8)
BEVEL HEIGHT MAX @45°	IN (MM)	1/4 (5.7)
BEVEL ANGLE		30° / 37.5° / 45°
RADIUS	IN (MM)	1/8 (3)
MILLING HEAD CONFIGURATION		3 x KX-Plate
SUPPORT PLATE DIAMETER	IN (MM)	4 5/8 (118)
CABLE W/PLUG	FT (M)	13 (4)
WEIGHT	LBS (KG)	10 (4.6)



PRICE INCLUDES: 1 KFH 17-8 RT**, 3 Clamping screw, 1 Copper paste, 1 Allen key 5 mm, 1 Torx screw driver TX15, 1 L-BOXX

Corded bevelers are sold without heads or inserts. Heads and inserts are material and angle specific. Please choose the appropriate head and insert on **page 38 for your application.

BEVELERS

FEIN corded and cordless Bevelers are an accurate and precise way to make bevels and radii on flat materials, sheet metal and containers, for inner and outer edges, contours, and rounding holes. A compact and lightweight design makes them perfect for tight spaces and fatigue-free work.

AKFH 17-15 RT BEVELER**

KIT PART NUMBER: 72381961090

SAFETY

With soft start, restart protection, blockage monitoring and electronic overload protection.

FUNCTIONAL

Produce chamfers and radii on inner and outer edges of flat materials.

FEIN ERGOGRIP

Ergonomic handle design. For efficient, that reduces fatigue. Maximum hold and control, even when wearing welders' gloves.

HIGH-PERFORMANCE MOTOR

Durable, overload protected FEIN motor with high copper content for maximum power. Designed for optimal air flow.

BOOSTER & SPRING TECHNOLOGY

Booster Technology offers significantly reduced vibration and chatter for improved performance while spring technology ensures safety and significantly reduces vibration by ensuring the rotational forces are cushioned.



KFH 17-15 RT		
INPUT POWER	W	1,500
POWER OUTPUT	W	835
NO LOAD SPEED	RPM	2,300 - 7,500
BEVEL LENGTH MAX @45°	IN (MM)	5/8 (15)
BEVEL HEIGHT MAX @45°	IN (MM)	7/16 (10.6)
BEVEL ANGLE		30° / 37.5° / 45°
RADIUS	IN (MM)	1/8 (3)
MILLING HEAD CONFIGURATION		3 x 2 KX-Plate
SUPPORT PLATE DIAMETER	IN (MM)	5-7/16 (137)
CABLE W/PLUG	FT (M)	13 (4)
WEIGHT	LBS (KG)	14 (6.4)







PRICE INCLUDES: 1 KFH 17-15 RT**, 6 Clamping screw, 1 copper paste, 1 Allen key 5 mm, 1 Torx screw driver TX15, 1 L-BOXX







Corded bevelers are sold without heads or inserts. Heads and inserts are material and angle specific. Please choose the appropriate head and insert on **page 38 for your application.



AKFH 18-5T ACCESSORIES

	DESCRIPTION	PART NUMBER
	Guide roller Ø 21.69 mm for 45° bevel and radius 2.5 mm (0.098")	64303001010
	Indexable insert SX for bevel for universal application (steel, millable stainless steels) (usable 8 times) (Package = 10 Pcs)	64302001010
	Indexable insert SX for R2.5 mm (0.098") for universal application (steel, millable stainless steels) (usable 8 times) (Package = 10 Pcs)	64302002010
	Clamping screw SX for indexable insert SX (Package = 10 Pcs)	31350076000

KFH 17-8 RT & KFH 17-15 RT ACCESSORIES

	DESCRIPTION	PART NUMBER
	Guide roller Ø 29.90 mm (1.177") for 30° and 37.5° bevel; no radius	64303002010
	Guide roller Ø 26.30 mm (1.035") for 45° bevel; no radius	64303003010
	Guide roller Ø 25.00 mm (0.984") for 60° bevel; no radius	64303008010
	Guide roller Ø 28.55 mm (1.124") for 45° bevel and radius 3 mm (0.118")	64303004010
	Indexable insert KX for bevel for universal application (steel) (usable 8 times) (Package = 10 Pcs)	64302004010
	Indexable insert KX for bevel for aluminum, non-ferrous metals, soft materials (usable 8 times) (Package = 10 Pcs)	64302003010
	Indexable insert KX for R3 mm (0.118") for universal application (steel) (usable 8 times) (Package = 10 Pcs)	64302006010
	Indexable insert KX for R4 mm (0.118") for universal application (steel) (usable 8 times) (Package = 10 Pcs)	64302017010
	Indexable insert KX for R3 mm (0.118") for aluminum, non-ferrous metals, soft materials (usable 8 times) (Package = 10 Pcs)	64302005010
	Clamping screw KX for indexable insert KX (Package = 10 Pcs)	31350075000

KFH 17-8 RT ACCESSORIES

	DESCRIPTION	PART NUMBER
	3 - insert milling cutter for 30° bevel	64301002010
	3 - insert milling cutter for 37.5° bevel	64301001010
	3 - insert milling cutter for 45° bevel and radius	64301002010

KFH 17-15 RT ACCESSORIES

	DESCRIPTION	PART NUMBER
	6 (3x2) - insert milling cutter for 30° bevel	64301004010
	6 (3x2) - insert milling cutter for 37.5° bevel	64301006010
	6 (3x2) - insert milling cutter for 45° bevel and radius	64301003010



METAL CUTTING SAWS

Slugger by FEIN metal cutting saws are built to stand up to whatever you can throw at them. With heavy-duty construction, heat free cutting and features that promote productivity and safety, it's no wonder Slugger by FEIN metal cutting saws are what the professionals use.

NEW!

THE NEW F IRON CUT 57 AS 6" CORDLESS METAL CUTTING SAW

KIT PART NUMBER: 71360462090
SELECT PART NUMBER: 71360461090

WORK SAFELY

Integrated chip collection keeps your job site clean.

QUALITY

Die cast aluminum housing and guard.



PRECISE

Straight cuts are made simple with the provided guide rail adapter.

- + Adjustable cutting depth up to 2-1/4"
- + Achieve straight, long, precise cuts with the provided guide rail adapter compatible with Makita, Bosch, Festool and Mafell guide rails
- + Average 150 cuts or 100' on a single 8Ah charge (3/32" mild steel)

KIT INCLUDES: 1 6" F-IRON Cut 57 AS, 1 Mild steel saw blade mounted, 1 5mm allen key, 1 Chip collection container, 1 Rip fence, 1 Guide rail adapter, 2, 8Ah CORE 18V batteries, 1 Fast charger, 1 L-Boxx pro tool case

6" Saw Capacities

Mild Steel - 15/16" | **Aluminum** - 1-1/2" | **Stainless Steel** - 1/4"

CONVENIENCE

Compatible with the 18V AMPShare battery platform.

F IRON CUT 75 ACCESSORIES

Guide Rail

31-1/2" guide rail for hand circular saws

PART NUMBER: 32133039000



Guide Rail Connector

Guide rail connector for hand circular saws

PART NUMBER: 32133040000



6" METAL SAW BLADES



	Part Number	Teeth	Arbor	Application
6" (150mm)	63502305000	30	3/4"	Mild steel up to 15/16" (24mm) solid material
	63502306000	32	3/4"	Aluminum up to 1-1/2" (40mm) solid material
	63502307000	30	3/4"	Stainless steel up to 1/8" (4mm) solid material



7-1/4" METAL CUTTING SAW

PART NUMBER: 69908120000

ERGONOMIC:

Well balanced handle design for better control.

WORK SAFELY

Integrated chip collection keeps your job site clean.



PRECISE

LED work light & laser guide for straight, accurate cuts (No batteries needed).

CONVENIENCE

Soft start motor with electric brake.

- + 2-1/2" maximum cutting depth
- + Bevel cut up to 45 degrees
- + Integrated chip collection keeps your job site clean
- + Leaves a workable edge when cutting steel plate, square tube, angle, pipe & tube

KIT INCLUDES: 1 7-1/4" Metal cutting saw, 1 blade, 1 wrench, 1 guide plate, 1 safety eyewear, 1 ear protection, 1 tool case

7-1/4" Saw Capacities

Mild Steel - 5/16" | Aluminum - 3/8" | Stainless Steel - 1/4"



7", 7-1/4" & 8" METAL SAW BLADES

	Part Number	Teeth	Arbor	Application
7" (180mm)	63502007500	36	3/4"	Mild steel up to 5/16" (8mm) solid material
	63502007510	54	3/4"	Aluminum up to 3/8" (9.5mm) solid material
	63502007520	48	3/4"	Stainless steel up to 1/4" (6mm) solid material
	63502007530	48	3/4"	Thin steel up to 1/4" (6mm) solid material
7 1/4" (185mm)	63502007200	36	3/4"	Mild steel up to 5/16" (8mm) solid material
	63502007210	54	3/4"	Aluminum up to 3/8" (9.5mm) solid material
	63502007220	48	3/4"	Stainless steel up to 1/4" (6mm) solid material
	69908120450	48	3/4"	Thin steel up to 1/4" (6mm) solid material
8" (203mm)*	69908120441	42	5/8"	Mild steel up to 5/16" (8mm) solid material

* Does not fit 7-1/4" Metal Cutting Saw



METAL CUTTING SAWS

Slugger by FEIN metal cutting saws are built to stand up to whatever you can throw at them. With heavy-duty construction, heat free cutting and features that promote productivity and safety, it's no wonder Slugger by FEIN metal cutting saws are what the professionals use.

9" METAL CUTTING SAW

PART NUMBER: 69908120001



CONVENIENCE

Soft start motor with electric brake.

PRECISE

LED work light & laser guide for straight, accurate cuts (No batteries needed).

WORK SAFELY

Integrated chip collection keeps your job site clean.

OPERATION

Smooth bevel and angle cutting adjustments.

- + Worm drive and oil bath gearbox makes for a longer lasting tool
- + Quick release depth adjustment for plunge cuts
- + 3-3/8" maximum cutting depth
- + Cutting surfaces are cool to the touch, allowing you to work faster and safer

KIT INCLUDES: 1 9" Metal cutting saw, 1 blade, 1 wrench, 1 guide plate, 1 safety eyewear, 1 ear protection, 1 tool case

9" Saw Capacities

Mild Steel - 1/2" | **Aluminum** - 5/8" | **Stainless Steel** - 5/16"



9" METAL SAW BLADES

	Part Number	Teeth	Arbor	Application
9" (230mm)	63502009540	48	1"	Mild steel up to 1/2" (12.7mm) solid material
	63502009550	60	1"	Aluminum up to 5/8" (15.9mm) solid material
	63502009560	60	1"	Stainless steel up to 5/16" (8mm) solid material
	69908120448	60	1"	Thin steel up to 1/4" (6mm) solid material



14" METAL CUTTING SAW

PART NUMBER: 72905361120

WORK SAFELY

Eye protection plate.

POWERFUL

Low speed, high torque motor for smooth, clean cuts.

CONVENIENCE

Smooth clamp adjustments to quickly go from one job to the next.

DURABLE

Rock solid cast iron design delivers less vibration for smooth clean cuts.



- + 5-1/8" maximum cutting depth
- + Chip collection tray keeps your job site clean
- + Cutting surfaces are cool to the touch, allowing you to work faster and safer
- + Depth stop allows you to consistently control your cut depth for reliable, precise cuts

KIT INCLUDES: 1 14" Metal cutting saw, 1 blade, 1 wrench, 1 table vise, 1 safety eyewear, 1 ear protection

14" Saw Capacities

Mild Steel - 1/2" | **Aluminum** - 5/8" | **Stainless Steel** - 5/16"

45°

Round - 4-1/8" | **Square** - 3-1/2" | **Rectangle** - 3-1/2" x 4-3/8"

90°

Round - 5-1/8" | **Square** - 4-3/4" | **Rectangle** - 3-3/4" x 7-1/4"



14" METAL SAW BLADES

	Part Number	Teeth	Arbor	Application
14" (355mm)	63502014600	66	1"	Mild steel up to 1/2" (12.7mm) solid material
	63502014610	80	1"	Aluminum up to 5/8" (15.9mm) solid material
	63502014620	90	1"	Stainless steel up to 5/16" (8mm) solid material
	63502014630	90	1"	Thin steel up to 1/4" (6mm) solid material

RECIPROCATING SAWS

Ideally suited for cutting pipes and profiles made of steel, cast iron, autoclaved aerated concrete and plastics.

ASTXE 649 ELECTRIC HACKSAW

PART NUMBER: 72342460090

MADE IN GERMANY



- + Electronic speed control for optimal cutting speed.
- + Adjustable clamping devices permit miter cuts up to 45° as well.
- + Straight cuts up to 24".

		ASTXE 649
Power consumption	W	750
Power output	W	480
Strokes	spm	100 - 350
Stroke of blade	in[mm]	2-1/4 [60]
Pipes up to Ø	in[mm]	15-3/4 [400]
Profiles up to W x H	in[mm]	11-1/2 [290] x 21-3/4 [550]
Cable with plug	ft[m]	8.2 [2.5]
Weight according to EPTA	lbs[kg]	14.11 [6.40]

STS 325R PNEUMATIC HACKSAW

PART NUMBER: 75340813000

MADE IN GERMANY

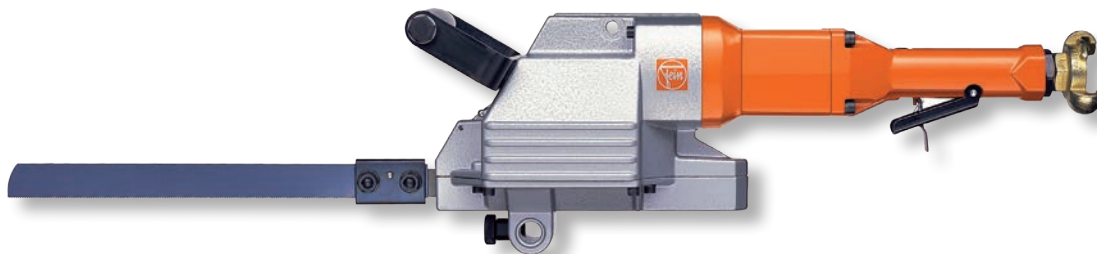

- + Adjustable clamping devices permit mitre cuts up to 45° as well.
- + Clamp and feed device available.
- + Adjustable clamping fixtures.

		STS 325R
Operating pressure	psi[bar]	87 [6.0]
Air consumption	cfm[m ³ /min]	51.2 [1.45]
Power output	W	1,100
Strokes	spm	330
Stroke of blade	in[mm]	2-1/4 [60]
Pipes up to Ø	in[mm]	17-1/4 [440]
Profiles up to W x H	in[mm]	11-1/2 [290] x 19-3/4 [500]
Weight according to EPTA	lbs[kg]	15.87 [7.20]



HACKSAW BLADES

Length, TPI and Blade Type - Sold individually

63503065009	8" L, 8 TPI, HSS
63503066002	8" L, 16 TPI, HSS
63503067006	8" L, 24 TPI, HSS
63503070000	12" L, 12 TPI, HSS
69908104003	12" L, 16 TPI, HSS
63503094002	12" L, 12 TPI, Tempered
63503093004	12" L, 16 TPI, Tempered
63503096018	13" L, 12 TPI, Boron
63503095006	15-3/4" L, 8 TPI, Tempered
63503068004	16" L, 8 TPI, HSS
63503064005	16" L, 16 TPI, HSS
69908104005	16" L, 16 TPI, Carbide
63503097012	19-1/4" L, 8 TPI, Boron
63503069008	21" L, 12 TPI, HSS
63503073006	24" L, 14 TPI, HSS
63503098001	24" L, 20 TPI, Tempered
69908104001	37" L, 12 TPI, HSS
69908104011	30" L, 12 TPI, HSS



HACKSAW ACCESSORIES



Small Pipe Clamp

Handles up to 6" pipes

PART NUMBER:
90702001001



Large Pipe Clamp

Handles up to 12 3/4" pipe.
Extension chain can be added
to expand capacity to 24"

PART NUMBER:
90702004006



18" Extension chain and bolt

Up to 18" diameter capacity when
added to pipe clamp 90702004006

PART NUMBER:
69908195291



24" Extension chain and bolt

Up to 24" diameter capacity when
added to pipe clamp 90702004006

PART NUMBER:
69908195290

NIBBLERS & SHEARS

Corrugated sheet metal, trapezoid sheet metal, steel plates, profiles or pipes – with FEIN, you always have the right cutting method at hand.

BLK 1.3 CSE NIBBLER

PART NUMBER: 72324260120

- + Indexable cutting direction
- + Variable speed motor
- + Up to 7.5ft/min cutting speed
- + Long life punch and die kit
- + Extra long 16ft power cord

Capacity:

Mild steel up to 18 gauge (1.3mm)
Stainless Steel up to 24 gauge (.6mm)



BLK 1.6 E NIBBLER

PART NUMBER: 72323860120

- + Indexable cutting direction
- + Variable speed motor
- + Up to 6.2ft/min cutting speed
- + Long life punch and die kit
- + Extra long 16ft power cord

Capacity:

Mild steel up to 16 gauge (1.6mm)
Stainless Steel up to 22 gauge (.75mm)



NIBBLER ACCESSORIES

Part Number	Description
30109169030	5 Punch/1 Die kit for BLK 1.3CSE
30109169009	1 Die for BLK 1.3 CSE
63602050000	1 Punch for BLK 1.3 CSE
63602048013	1 Punch/1 - Die kit for 1.6E Nibbler
30109141003	1 Die for BLK 1.6E
63602048004	1 Punch for BLK 1.6E
92602071019	1 Profil-Kit extension 160

BLS 1.6 E SHEET METAL SHEAR

PART NUMBER: 72303461090

- + Engineered for distortion free cutting
- + Cuts straight lines and curves
- + Variable speed motor
- + Design allows for full visibility of cutting line
- + 4 sided indexable cutting blades for long life
- + Extra long 16ft power cord

Capacity:

Mild steel up to 16 gauge (1.6mm)
Stainless Steel up to 20 gauge (1.0mm) 20



BSS 1.6 E SLITTING SHEAR

PART NUMBER: 72303161090

- + Engineered for distortion free cutting
- + Variable speed motor
- + Design allows for full visibility of cutting line
- + Long life cutting blade
- + Extra long 16ft power cord

Capacity:

Mild steel up to 16 gauge (1.6mm)
Stainless Steel up to 19 gauge (1.0mm)



SHEAR ACCESSORIES

Part Number	Description
31308072000	BLS 1.6E standard shear replacement blade - single blade
31308153014	BSS 1.6E slitting shear Cutting bars - pair
31308152001	BSS 1.6E slitting shear Cutter blade (for Stainless steel up to .031" thickness)
31308123008	BSS 1.6E slitting shear Cutter blade (for Stainless steel up to .051" thickness)
31308151008	BSS 1.6E slitting shear Cutter blade (for mild steel up to .039" thickness)
31308150009	BSS 1.6E slitting shear Cutter blade (for mild steel up to .063" thickness)



BLK 3.5 E NIBBLER

PART NUMBER: 72324661090

- + Cuts through grooves and cut-outs in sheet metals, tool can turn on the spot.
- + Adjustable cutting direction in three 90° steps
- + Chip protection mesh on vent slots

Capacity:

Mild steel up to 10 gauge (3.2mm)
Stainless Steel up to 14 gauge (1.8mm)

Mild steel punch and die: Punch - 31309097002 Die - 31309093003	Stainless steel punch and die: Punch - 31309098000 Die - 31309094001
---	--



BLK 5.0 NIBBLER

PART NUMBER: 72324761090

- + Indexable cutting direction
- + Powerful 1,700W Motor
- + Up to 4.9 ft/min cutting speed
- + Long life punch and die kit
- + Extra long 16ft. Power Cord

Capacity:

Mild steel up to 6 gauge (5.0mm)
Stainless Steel up to 13 gauge (2.5mm)

For 1/4" mild steel thickness: Punch - 31309110004 Die - 31309109002	For stainless steel: Punch - 31309134006 Die - 31309108008
--	--

AMPSHARE CORDLESS NIBBLERS AND SHEARS



ABLK 18 1.3 CSE NIBBLER

KIT PART NUMBER: 71320565090
SELECT PART NUMBER: 71321061090

- + Indexable cutting direction
- + Variable speed motor
- + Up to 7.5ft/min cutting speed
- + Long life punch and die kit
- + Includes additional (5) punch and (1) die kit (30109169030)

Capacity:

Mild steel up to 18 gauge (1.3mm)
Stainless Steel up to 24 gauge (.6mm)



ABLK 18 1.6 E NIBBLER

KIT PART NUMBER: 71320465090
SELECT PART NUMBER: 71321161090

- + Indexable cutting direction
- + Variable speed motor
- + Up to 6.2ft/min cutting speed
- + Long life punch and die kit
- + Includes additional punch and die kit (63602048013)

Capacity:

Mild steel up to 16 gauge (1.6mm)
Stainless Steel up to 22 gauge (.75mm)



ABSS 18 1.6 E SLITTING SHEAR

KIT PART NUMBER: 71300565090
SELECT PART NUMBER: 71300561090

- + Cuts straight lines and curves
- + Variable speed motor
- + Engineered for distortion free cutting
- + Design allows for full visibility of cutting line
- + Long life cutting blade
- + Includes additional cutting blade (31308151008)

Capacity:

Mild steel up to 16 gauge (1.6mm)
Stainless Steel up to 19 gauge (1.0mm)



ABLS 18 1.6 E SHEET METAL SHEAR

KIT PART NUMBER: 71300665090
SELECT PART NUMBER: 71300661090

- + Cuts straight lines and curves
- + Variable speed motor
- + Engineered for distortion free cutting
- + Design allows for full visibility of cutting line
- + 4 sided indexable cutting blades for long life
- + Includes additional cutting insert (31308072000)

Capacity:

Mild steel up to 16 gauge (1.6mm)
Stainless Steel up to 19 gauge (1.0mm)



****All nibbler and shear kits contain (2) 4Ah CORE 18V batteries, (1) Rapid charger (92604334010), (1) marker and (1) roll of tape.****

VERSAMAG

Boost productivity and increase jobsite safety by taking the vise wherever you need it.

NEW!



VERSAMAG SYSTEM

MANEUVERABILITY IN MIND

Strong Permanent Magnet provides 1,750lb holding force on 1" steel plate. Magnet can also be easily adjusted.

ALL METAL CONSTRUCTION

Multi-function jaw quickly grips workpieces safely. Large 4.25" jaw capacity.

PRECISION

Machined surface provides smooth jaw action while clamping.



EASY TO OPERATE

Tool-free set up with everything you need stored on VersaMAG.

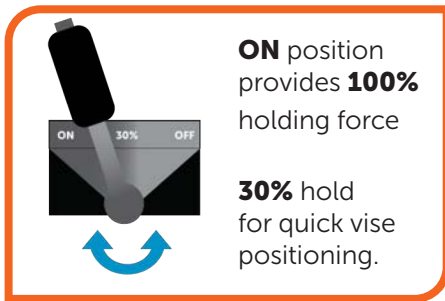

ON position provides **100%** holding force

30% hold for quick vise positioning.

TECHNICAL DATA	VersaMAG permanent magnet with vise
JAW HEIGHT (IN)	1.57"
CLAMPING WIDTH (IN)	4.25"
MAGNETIC FOOT DIMENSIONS (IN)	8.35" x 2.75"
MAGNETIC HOLDING FORCE (LBF.)	1,750
WEIGHT (LBS)	16
JAW WIDTH (IN)	3.94"
INCLUDES	1x permanent magnet, 1x vise, 1x socket head wrench (3 mm), 1x safety strap
PART NUMBER	90701004020



VersaMAG ACCESSORIES



2-1/3 inch oversized jaw for FEIN VersaMAG

PART NUMBER: 32422420010
Perfect for machining larger flat and round materials with a diameter of up to 4 inches. Only compatible with the FEIN VersaMAG vise.

NEW!



Aluminium (p) prism & (b) blank jaws for FEIN VersaMAG

PART NUMBER: 90701010010
Flat material can be clamped with ease thanks to the 90° milled slot at the top. No scratching of the material – superlative quality even with sensitive workpieces, such as stainless steel, aluminium or plastics. Only compatible with the FEIN VersaMAG.



Welding plate for FEIN VersaMAG

PART NUMBER: 90701005020
Long-life welding plate with a hole diameter of 5/8" on a 10 x 10in. plate. Plasmatized product for good surface protection, also features a prefabricated drill pattern for Demmeler and Siegmund elements. Only compatible with the FEIN VersaMAG.

NEW!



Universal panel for FEIN VersaMAG

PART NUMBER: 90701008030
Ultimate convenience with the VersaMAG universal plate. Easy attachment of measuring devices, tablets or phones for hands-free use on any magnetic surface. Only compatible with the FEIN VersaMAG.

HAND HELD DRILLS

FEIN is known worldwide for its quality and dependable drilling solutions. We have one of the best selections of corded drills on the market today.

MADE IN GERMANY

BOP 10 HAND DRILL - 3/8"

PART NUMBER: 72055360090

- + Precision, all metal 3/8" 3-jaw chuck
- + Reversible
- + FEIN high performance motor with speed stability for constant drilling
- + Adjustable handle
- + Speed: 0 - 1,500 RPM
- + Extra long 16ft power cord



BOP 13-2 HAND DRILL - 1/2"

PART NUMBER: 72055560090

- + Precision, all metal 1/2" 3-jaw chuck
- + Mechanical, 2-speed gearbox with speed adjustment
- + Reversible
- + FEIN high performance motor with speed stability for constant drilling
- + Adjustable handle
- + Variable speed: 0 - 680 / 0 - 2,200 RPM
- + Extra long 16ft power cord



BOS 16 HAND DRILL - 5/8"

PART NUMBER: 72054760090

- + Precision, all metal 5/8" 3-jaw chuck
- + Reversible
- + FEIN high performance motor with speed stability for constant drilling
- + Adjustable handle
- + Speed: 0 - 520 RPM
- + Extra long 16ft power cord



BOS 16-2 HAND DRILL - 5/8"

PART NUMBER: 72054960090

- + Precision, all metal 5/8" 3-jaw chuck
- + Mechanical, 2-speed gearbox with speed adjustment
- + Reversible
- + FEIN high performance motor with speed stability for constant drilling
- + Adjustable handle
- + Variable speed: 0 - 520 / 0 - 1,600 RPM
- + Extra long 16ft power cord



MAG DRILLS



Slugger by FEIN offers more magnetic base drills for more applications, providing the right tool for every job. All Slugger by FEIN magnetic base drills reduce downtime with 100% duty cycle, high-performance, high torque motors.

ENDURANCE DRILLS

Maximum durability and portability make the Slugger Endurance series magnetic base drills the ultimate drills for any heavy drilling situation. Quality, superior durability and essential functionality, these drills are more than capable of handling any drilling task.

- + High performance, 100% duty cycle motors designed for all day hole making.
- + Lightweight, ergonomic drill stands.
- + Easily accessible controls for motor and magnet.
- + Feed handle can be changed to either side.
- + Drill chuck and countersink accessories available.

NEW!



JME SHORTSLUGGER II

PART NUMBER: 72709461090

- + Extra-durable gearbox design with up to 400 hours of operation time
- + Internal motor cord
- + Tilt sensor safety shut off
- + Coolant tank included
- Capacity:** 1-1/4" x 2"
- Stroke length:** 3-9/16"
- Weight:** 23.8 lb
- Recommended Cutters:** HSS



JME HOLEMAKER III

PART NUMBER: 72705961090

- + Optimal RPM's for both HSS and Carbide cutters
- + Double dovetail design for use with longer tooling
- + Pivoting motor cable
- + Coolant tank included
- Capacity:** 1-3/8" x 2"
- Stroke length:** 5-11/16"
- Stroke range:** 10-1/4"
- Weight:** 25.8 lb
- Recommended Cutters:** HSS/Carbide



JHM USA 101

PART NUMBER: 72725261124

- + Solid die-cast aluminum construction
- + Smart magnet safety circuitry
- + Uniform torque motor ideal for HSS cutters
- + Positive slug ejection
- + Coolant tank included
- Capacity:** 1-1/2" x 2"
- Stroke length:** 2-9/16"
- Weight:** 31.75 lb
- Recommended Cutters:** HSS



JME USA 202 M

PART NUMBER: 72706961090

- + Mechanical 2-speed gearbox
- + Optimal for both HSS and Carbide
- + Pivoting motor cable
- + Coolant tank included
- Capacity:** 2" x 2"
- Stroke length:** 5-5/16"
- Stroke range:** 10-1/4"
- Arbor:** #3 Morse taper
- Weight:** 30.9 lb
- Recommended Cutters:** HSS/Carbide

NEW!



JME MAGSPEED 150

PART NUMBER: 72732461090

- + Outstanding cutting performance with cutting speeds of up to 230 ft/min with stable speed and torque curve
- + Reduce drilling times up to 50% over conventional HSS mag drills when using TCT and coated TCT cutters
- + Tilt sensor safety shut off
- + Integrated cooling tank
- + Brushless motor
- Capacity:** 1-1/2" x 2"
- Stroke length:** 4-3/16"
- Weight:** 24.25 lb
- Recommended Cutters:** TCT/Coated TCT carbide

CUT DRILLING TIMES BY 50%!

*VS HSS STEEL



REQUEST A DEMO

UNIVERSAL DRILLS

Universal drills with functionality in mind and outstanding performance with quality and technology to boot. The Slugger Universal series magnetic base drill series offers the precision tools needed to complete any job with repeatability and consistency.

- + High performance, 100% duty cycle motors designed for all day hole making.
- + Lightweight, ergonomic drill stands.
- + Universal functionality for drilling, tapping, reaming and countersinking.
- + Double dovetail design for longer tooling.



JMU 137 MQW

PART NUMBER: 72705661120

- + Tilt sensor safety shutoff
- + Electronic speed and reversing motor controls
- + Coolant tank included
- Capacity:** 1-3/8" x 2"
- Stroke length:** 5-5/16"
- Stroke range:** 10-1/4"
- Weight:** 23.6 lb
- Recommended Cutters:** HSS/Carbide



JMU 137-2 QW

PART NUMBER: 72705861120

- + Tilt sensor safety shutoff
- + Mechanical 2 speed gearbox designed for small twist drills and annular cutters
- + Electronic speed and reversing motor controls
- + Coolant tank included
- Capacity:** 1-3/8" x 2"
- Stroke length:** 5-5/16"
- Stroke range:** 10-1/4"
- Weight:** 24.5 lb
- Recommended Cutters:** HSS/Carbide



JMU 137 PQW

PART NUMBER: 72707361090

- + Tilt sensor safety shut off
- + Permanent magnet
- + Electronic speed and reversing motor controls
- + Coolant tank included
- Capacity:** 1-3/8" x 2"
- Stroke length:** 5-5/16"
- Stroke range:** 10-1/4"
- Weight:** 27.5 lb
- Recommended Cutters:** HSS/Carbide



JCM 200 U

PART NUMBER: 72704461120

- + Extra large stroke for all drilling work
- + High-power motor with stable speed
- + Electronic speed and reversing motor controls
- + Coolant tank included
- Capacity:** 2" x 2"
- Stroke length:** 5-11/16"
- Stroke range:** 12-3/8"
- Weight:** 32.1 lb
- Recommended Cutters:** Carbide



JCM 256 U

PART NUMBER: 72704761120

- + Extra large stroke for all drilling work
- + High-power motor with stable speed
- + Electronic speed and reversing motor controls
- + Coolant tank included
- Capacity:** 2-9/16" x 2"
- Stroke length:** 5-11/16"
- Stroke range:** 12-3/8"
- Arbor:** #3 Morse taper
- Swivel base:** 7 degrees
- Weight:** 36.75 lb
- Recommended Cutters:** Carbide



JMU 404 M

PART NUMBER: 72706061090

- + Mechanical 4-speed gearbox
- + FEIN 1,700 W high-performance, high torque motor
- + Torque slip clutch
- + Coolant tank included
- Capacity:** 4-5/16" x 4"
- Stroke length:** 11"
- Stroke range:** 15-3/4"
- Arbor:** #4 Morse taper
- Weight:** 79.4 lb
- Recommended Cutters:** HSS/Carbide

SPECIALTY MAG DRILLS



Slugger by FEIN offers more magnetic base drills for more applications, providing the right tool for every job. All Slugger by FEIN magnetic base drills reduce downtime with 100% duty cycle, high-performance, high torque motors.

COMPACT DRILLS

Compact and adaptable, the perfect workhorse for tight spaces that need precise results. Where other magnetic drills just can't fit, the Compact series is there to get even the tightest job done.

NEW!



JMC MAGFORCE 90

PART NUMBER: 72732362090

- + Smallest magnetic base drill with forward/reverse rotation
 - + Powerful 1,150 watt brushless motor
 - + Tilt sensor safety shutoff
 - + Ratcheting handle allows work in even the tightest places
 - + Coolant bottle included
- Capacity:** 1-3/8" x 1-3/8"
Stroke length: 1-13/16"
Weight: 18.75 lb

Recommended Cutters: HSS/Carbide



JHM MAGFORCE

PART NUMBER: 72725361127

- + Compact with ideal power to weight ratio for work in small spaces
 - + Stationary drill motor with positive slug ejection
 - + Solid die-cast aluminum construction
 - + Smart magnet safety circuitry
 - + Coolant tank included
- Capacity:** 1-5/8" x 2"
Stroke length: 2-9/16"
Weight: 28.8 lb

Recommended Cutters: HSS/Carbide

AUTOMATIC DRILL

Save time and money while getting precise, repeatable results with the automatic drilling functionality of the Automatic series drills.



JCM 200 AUTO

PART NUMBER: 72704661120

- + Tilt sensor safety shutoff
 - + Mechanical 2-gearbox
 - + Repeatable and consistent drilling times
 - + Coolant tank included
- Capacity:** 2" x 2"
Stroke length: 5-11/16"
Stroke range: 12-3/8"
Arbor: #3 Morse taper
Weight: 35.7 lb

Recommended Cutters: Carbide

CORDLESS DRILLS

Speed and efficiency meet portability with the Slugger Cordless series. The cordless line offers the same quality and performance as its corded variants but in a convenient, manageable drill.

NEW!



AJMU 137 PMQW

SELECT PART NUMBER: 71700562090
KIT PART NUMBER: 71700563090



- + Powerful and lightweight FEIN Power Drive brushless motor and FEIN HighPower battery
- + Permanent magnet
- + Universal functionality for drilling, tapping, reaming and countersinking
- + Coolant tank included

Capacity: 1-3/8" x 2"

Stroke length: 5-5/16"

Stroke range: 10-1/4"

Weight (w/o battery): 26.7 lb

Recommended Cutters: HSS/Carbide

KIT INCLUDES: 1 AJMU 137 PMQW cordless mag drill, 1 coolant pump, 1 safety strap, 1 chip hook, 1 centering pin dia. 1/4 x 3-9/16 in, 1 centering pin dia. 1/4 x 3-1/4 in, 1 centering pin dia. 1/4 x 4 in, 1 chip guard, 1 drift, 2 CORE 18 V / 8.0 Ah Li-Ion batteries, 1 GAL18 V-160 AS rapid charger, 1 tool case

NEW!



AJMU 137 PMQW + 6-PIECE CUTTER SET

PART NUMBER: 71700564090

KIT INCLUDES: 1 AJMU 137 PMQW cordless mag drill, 1 coolant pump, 1 safety strap, 1 chip hook, 1 centering pin dia. 1/4 x 3-9/16 in., 1 centering pin dia. 1/4 x 3-1/4 in., 1 centering pin dia. 1/4 x 4 in., 1 chip guard, 1 drift, 2 CORE 18 V / 8.0 Ah Li-Ion batteries, 1 GAL18 V-160 AmpShare rapid charger, 1 tool case, 1 Magbrush, 1 cutting paste, 5 HSS NOVA annular cutters 2 in. cutting depth (9/16, 11/16, 13/16, 15/16, 1-1/16 in), 1 L-BOXX 136

MAG DRILL ACCESSORIES



MAG DRILL ACCESSORIES

Part Number	Description
64201002980	Slugger by FEIN Magbrush - 15" Reach
64201003980	Slugger by FEIN Magbrush - 36" Reach
64298190100	1/2" chuck and adapter for USA-101
69908195346	1/2" Drill Chuck with 3/4" straight shank. For all drills except: ShortSlugger II, MagForce, MagForce90, USA-101
69908195275	5/8" Drill chuck with 3/4" straight shank. For all drills except: ShortSlugger II, MagForce, MagForce90, USA-101
Cutting Fluid & Paste	
32132032980	Slugger by FEIN Cutting Fluid - 1 Qt. bottle
32160015980	Slugger by FEIN Cutting Paste - 10 oz. Tube
64298102080	Slugger by FEIN Cutting Fluid - 1 Gallon bottle
32132032982	Cutting fluid (12 qt case)
64298102084	Cutting fluid (4 gal case)
64298102090	Cutting fluid (5 gal bucket)
32160015982	Slugger cutting paste (12 - 10oz tubes)



ARBOR EXTENSIONS

Arbor body diameter is 1-5/16"



Part Number	Description
63106020980	2" arbor extension
63106021980	3" arbor extension
63106022980	4" arbor extension
63106023980	6" arbor extension

SUCTION PLATE

Part Number	Description
92602054016	For non-magnetic materials, 9-3/16 x 13 x 4-5/16 in [250 x 330 x 110 mm]. (270lbs of holding force)



PIPE DRILLING DEVICE

Part Number	Description
92602055010	Including clamping strap, for drilling holes in pipe with Ø from 2-3/8 to 11-13/16 in [60 to 300 mm], 8-11/16 x 5-1/8 in [220 x 130 mm]



APPLICATION & MACHINE SELECTION

	HSS CUTTERS	CARBIDE CUTTERS
QUICK COMPARISON	<ul style="list-style-type: none"> + General fabrication + Can be resharpened up to 6 times. + Lowest cost per hole < 1-1/8" Ø 	<ul style="list-style-type: none"> + General/structural, stainless steel and exotic metals + Lowest cost per hole > 1-1/8" Ø + Faster cut
RECOMMENDED MACHINES All drills run HSS & carbide	<ul style="list-style-type: none"> + JME ShortSlugger II + JHM USA 101 + JHM Magforce 	<ul style="list-style-type: none"> + JMU 137 series (4 models) + JCM series (200, 256, 200 auto) + JMU 404 + JME Magspeed 150
	<ul style="list-style-type: none"> + JME Holemaker III + JME USA 202 + JMC Magforce 90 	
COMPETITOR MACHINES	<ul style="list-style-type: none"> + Slugger cutters use an industry standard shank. + Will fit most competitor machines* 	

Wide range of applications

Use annular cutters with mag drills for a wide range of tasks, from drilling in steel girders to overlapping holes, drilling in multi-layer materials and offset stop-drilling.



*Adaptor needed for some drills

MAG DRILL CUTTERS



Slugger annular cutters, combined with Slugger magnetic base drills, create a cost-effective, high-performance system.

HIGH SPEED STEEL CUTTERS

MADE IN USA



HELICAL FLUTE DESIGN

Wide flutes reliably evacuate the chips out of the hole. Fast, efficient chip removal with minimum contact between the cutter and drill hole for low torque and power consumption.

HIGH PERFORMANCE

All cutting teeth have the same geometry which helps to produce clean, burr-free holes while still allowing for a fast, smooth cut.

INDUSTRY STANDARD

2 flat 3/4 in straight shank for use with most commercially available magnetic drills.

100% HEAT TREATED THROUGHOUT

Internal vacuum heat treatment for consistent performance and longer service life. Cutters can also be resharpened up to 6 times.

Description	1" DOC	2" DOC
7/16" HSS with pilot pin	63134111041	63134111042
1/2" HSS with pilot pin	63134127041	63134127042
9/16" HSS with pilot pin	63134143041	63134143042
5/8" HSS with pilot pin	63134158041	63134158042
11/16" HSS with pilot pin	63134175041	63134175042
3/4" HSS with pilot pin	63134191041	63134191042
13/16" HSS with pilot pin	63134206041	63134206042
7/8" HSS with pilot pin	63134222041	63134222042
15/16" HSS with pilot pin	63134238041	63134238042
1" HSS with pilot pin	63134254041	63134254042
1-1/16" HSS with pilot pin	63134269041	63134269042
1-1/8" HSS with pilot pin	63134286041	63134286042
1-3/16" HSS with pilot pin	63134302041	63134302042
1-1/4" HSS with pilot pin	63134318041	63134318042
1-5/16" HSS with pilot pin	63134333041	63134333042
1-3/8" HSS with pilot pin	63134349041	63134349042
1-7/16" HSS with pilot pin	63134365041	63134365042
1-1/2" HSS with pilot pin	63134381041	63134381042
1-9/16" HSS with pilot pin	63134397041	63134397042
1-5/8" HSS with pilot pin	63134413041	63134413042
1-11/16" HSS with pilot pin	63134429041	63134429042
1-3/4" HSS with pilot pin	63134445041	63134445042
1-13/16" HSS with pilot pin	63134460041	63134460042
1-7/8" HSS with pilot pin	63134476041	63134476042
1-15/16" HSS with pilot pin	63134492041	63134492042
2" HSS with pilot pin	63134508041	63134508042
2-1/16" HSS with pilot pin	63134524041	63134524042



HIGH SPEED STEEL ID GRIND WITH TIN COATING CUTTERS*

Description	1" DOC	Description	1" DOC
9/16" IDTN	63134142113	7/8" IDTN	63134222107
5/8" IDTN	63134158106	15/16" IDTN	63134238115
11/16" IDTN	63134174119	1" IDTN	63134254108
3/4" IDTN	63134190109		

*1" DOC ID TIN coated cutters do not come with a pilot pin. Pilot pin needed, PN 63134998300



CARBIDE CUTTERS



HELICAL FLUTE DESIGN

Wide flutes reliably evacuate the chips out of the hole. Fast, efficient chip removal with minimum contact between the cutter and drill hole for low torque and power consumption.

DESIGNED FOR DRILLING AT HIGHER RPM'S

Allowing you to make more holes much faster.

UNIVERSAL SHANK

2 flat 3/4 in straight shank with dentents for use with most commercially available magnetic drills.

DURABILITY

All cutting teeth have the same geometry which helps to produce clean, burr-free holes. Carbide makes for a longer lasting cutter and is ideal for harder materials and higher RPMs.

Description	1" DOC*	1-3/8" DOC	2" DOC
9/16" Carbide Cutter with pilot pin	63127561110*	63135143021	63135143022
5/8" Carbide Cutter with pilot pin	63127562110*	63135159021	63135159022
11/16" Carbide Cutter with pilot pin	63127563110*	63135175021	63135175022
3/4" Carbide Cutter with pilot pin	63127564110*	63135191021	63135191022
13/16" Carbide Cutter with pilot pin	63127565110*	63135206021	63135206022
7/8" Carbide Cutter with pilot pin	63127566110*	63135222021	63135222022
15/16" Carbide Cutter with pilot pin	63127567110*	63135238021	63135238022
1" Carbide Cutter with pilot pin	63127568110*	63135254021	63135254022
1-1/16" Carbide Cutter with pilot pin	63127569110*	63135269021	63135269022
1-1/8" Carbide Cutter with pilot pin	63127570110*	63135286021	63135286022
1-3/16" Carbide Cutter with pilot pin	63127571110*	63135302021	63135302022
1-1/4" Carbide Cutter with pilot pin	63127572110*	63135318021	63135318022
1-5/16" Carbide Cutter with pilot pin	63127573110*	63135333021	63135333022
1-3/8" Carbide Cutter with pilot pin	63127574110*	63135349021	63135349022
1-7/16" Carbide Cutter with pilot pin	-	63135365021	63135365022
1-1/2" Carbide Cutter with pilot pin	-	63135381021	63135381022
1-9/16" Carbide Cutter with pilot pin	-	63135397021	63135397022
1-5/8" Carbide Cutter with pilot pin	-	63135413021	63135413022
1-11/16" Carbide Cutter with pilot pin	-	63135429021	63135429022
1-3/4" Carbide Cutter with pilot pin	-	63135445021	63135445022
1-13/16" Carbide Cutter with pilot pin	-	63135461021	63135461022
1-7/8" Carbide Cutter with pilot pin	-	63135476021	63135476022
1-15/16" Carbide Cutter with pilot pin	-	63135492021	63135492022
2" Carbide Cutter with pilot pin	-	63135508021	63135508022
2-1/16" Carbide Cutter with pilot pin	-	63135524021	63135524022

*1" DOC TCT do not come with a pilot pin. Pilot pin needed, PN: 63134998300

NEW!

COATED CARBIDE CUTTERS

Extreme durability: Coated carbide cutters reduce heat and extend life of the cutter, especially when drilling hard to cut materials.



Description	1-3/8" DOC	Description	1-3/8" DOC
9/16" x 1-3/8" with pilot pin	63127839003	1 1/16" x 1-3/8" with pilot pin	63127839013
5/8" x 1-3/8" with pilot pin	63127839004	1 1/8" x 1-3/8" with pilot pin	63127839016
11/16" x 1-3/8" with pilot pin	63127839006	1 3/16" x 1-3/8" with pilot pin	63127839017
3/4" x 1-3/8" with pilot pin	63127839007	1 1/4" x 1-3/8" with pilot pin	63127839018
13/16" x 1-3/8" with pilot pin	63127839009	1 5/16" x 1-3/8" with pilot pin	63127839019
7/8" x 1-3/8" with pilot pin	63127839010	1 3/8" x 1-3/8" with pilot pin	63127839021
15/16" x 1-3/8" with pilot pin	63127839011	1 7/16" x 1-3/8" with pilot pin	63127839022
1" x 1-3/8" with pilot pin	63127839012	1 1/2" x 1-3/8" with pilot pin	63127839023

MAG DRILL CUTTERS



Sluggerr annular cutters, combined with Sluggerr magnetic base drills, create a cost-effective, high-performance system.



TWIST DRILL SETS - 3/4" STRAIGHT SHANK

Description	2" DOC
Standard set, 1/4", 5/16", 3/8", 7/16"	64298050000
1/4"	64298050020
5/16"	64298050040
3/8"	64298050030
7/16"	64298050050

Description	1-3/8" DOC
1/4"	63111029010
3/8"	63111030010
5/16"	63111031010
7/16"	63111032010
9/16"	63111033010

SLUGGER CUTTER SETS

Find the cutter set that works for you. With Sluggerr's dynamic cutter offerings, coupled with the unmatched quality and durability of Sluggerr magnetic base drills, finding the right combination for any job has never been easier.



5 piece universal shank carbide cutter set - 2" DOC
PART NUMBER: 63135999010
 3/4" shankset includes diameters: 9/16", 11/16", 13/16", 15/16", 1-1/16". Includes case, pilot pin.



5 piece HSS structural cutter set 1" DOC
PART NUMBER: 63134999010
 3/4" shankset includes diameters: 9/16", 11/16", 13/16", 15/16", 1-1/16". Includes case, pilot pin.



5 piece HSS Structural cutter set 2" DOC
PART NUMBER: 63134999015
 3/4" shank set includes diameters: 9/16", 11/16", 13/16", 15/16", 1-1/16". Includes case, pilot pin.



11 piece HSS 1" DOC cutter set (7/16" - 1-1/16")
PART NUMBER: 63134999020
 3/4" shankset includes diameters: 7/16", 1/2", 9/16", 5/8", 11/16", 13/16", 3/4", 13/16", 7/8", 15/16", 1", 1-1/16". Includes pilot pin for 7/16" to 1/2" cutter Ø, pilot pin for 9/16" to 1-1/16" cutter Ø, case.



11 piece HSS 2" DOC cutter set (7/16" - 1-1/16")
PART NUMBER: 63134999026
 3/4" shank set includes diameters: 7/16", 1/2", 9/16", 5/8", 11/16", 13/16", 3/4", 13/16", 7/8", 15/16", 1", 1-1/16". Includes pilot pin for 7/16" to 1/2" cutter Ø, pilot pin for 9/16" to 1-1/16" cutter Ø, case.

SLUGGER BY FEIN ANNULAR CUTTERS



With over 40 years of annular cutter manufacturing and design experience, we are the industry experts in hole-making. Our annular cutters are not only made in the USA, they are 3-4x faster and more precise than twist drilling, and leave smooth, burr-free holes. And because our cutters are high quality and able to be resharpened, they last longer, resulting in a lower cost per hole for you.



WHEN YOU BUY SLUGGER BY FEIN, YOU DEAL DIRECTLY WITH A MANUFACTURER IN THE USA.

Slugger by FEIN stocks the largest, most varied offering of annular cutters sizes. If we don't stock what you need, we can produce it.

Custom cutters for any specialty application:

- + Ranging from 7/16" – 4" in diameter
- + Ranging from 1/2" – 6" depth of cut
- + Non-standard geometries
- + Specialty coatings
- + Non-Standard shank sizes and shapes
- + Cutters with special wall thickness

CALL US AT:

1-800-441-9878
TO FIND A CUTTER
THAT FIT YOUR NEEDS!

*Minimum order quantity: 6. Shipment depends on custom cutter requirements.



High Speed Steel Cutters (HSS)

- + Standard material used to manufacture Slugger cutters.
- + Ideal for drilling structural steel.



High Speed Steel Cutters (ID Geometry)

- + Convenient when drilling through multiple layers.



High Speed Steel Cutters (Titanium Nitride)

- + Improves tool life by increasing surface hardness of tool, providing greater lubricity.



High Speed Steel Cutters (Titanium Nitride, cobalt steel cutters)

- + Improve tool life by increasing surface hardness of the tool and providing greater lubricity.



High Speed Steel Cutters (Titanium Carbonitride, coated)

- + Practical when drilling highly abrasive or gummy materials, such as brass, aluminum alloys and cast iron.



Cobalt Steel Cutters (M42)

- + Efficient when drilling materials are inconsistent.
- + Contain the highest amount of cobalt.
- + Extending tool life between sharpening.



Universal Shank Carbide Cutters

- + Ideal for cutting harder materials.
- + Designed for drilling higher RPM'S when increased hole making is desired.



Coated Carbide Cutters

- + Ideal for cutting harder materials.
- + Reduce heat and extend life of the cutter

ROTO-STAR WELDING POSITIONERS

The Roto-Star weld positioners are designed to not only provide a stable work platform, but also allow for achieving cleaner, stronger welds.

ROTO-STAR WITH CHUCK

	ROTO-STAR I	ROTO-STAR III
Chuck	6"	8"
Swing at 0°	16"	20"
Vertical weight capacity	200 lbs.	250 lbs.
Horizontal weight capacity	100 lbs.	150 lbs.
Thru spindle part capacity	1 ½" diameter	2 ½" diameter
Spindle Rotation	360°	360°
Spindle speed	0 to 10 RPM	0 to 8 RPM
Angle adjustment	0 to 90°	0 to 90°
Grounding capacity	300A	300A
Voltage	120v	120v
Shipping weight	60 lbs.	90 lbs.
Optional rotary plate	12" diameter	16" diameter

Part Number	Model	Description
31343790030	ROTO 1	Positioner w/chuck
31343790130	ROTO 1-V	Positioner w/chuck, and variable speed foot pedal
31343790140	ROTO 3	Positioner w/chuck
31343790260	ROTO 3-V	Positioner w/chuck, and variable speed foot pedal

ROTO-STAR WITH FACEPLATE

	ROTO-STAR I - P	ROTO-STAR III - P
Chuck	-	-
Swing at 0°	16"	20"
Vertical weight capacity	200 lbs.	250 lbs.
Horizontal weight capacity	100 lbs.	150 lbs.
Thru spindle part capacity	-	-
Spindle Rotation	360°	360°
Spindle speed	0 to 10 RPM	0 to 8 RPM
Angle adjustment	0 to 90°	0 to 90°
Grounding capacity	300A	300A
Voltage	120v	120v
Shipping weight	45 lbs.	65 lbs.
Fixed rotary plate	12" diameter	16" diameter

Part Number	Model	Description
31343690090	ROTO 1-P	Positioner w/plate, and foot pedal
31343790120	ROTO 1-P-V	Positioner w/plate, and variable speed foot pedal
31343790210	ROTO 3-P	Positioner w/plate
31343790250	ROTO 3-P-V	Positioner w/plate, and variable speed foot pedal



ROTO-STAR I



ROTO-STAR III

MADE IN USA



Variable speed control box (included with RotoStar I & III select models only)

- + Increase welding productivity and quality.
- + Available with chuck or plate.
- + Built-in variable speed.
- + Forward, reverse
0-8 RPM (ROTO I)/
0-10 RPM (ROTO 3).
- + 0°-90° at 15° increments at base.



ROTOSTAR ACCESSORIES



12" Surface Plate
PART NUMBER:
 31343710010



16" Surface Plate
PART NUMBER:
 31343710030



Variable speed foot pedal with control box
PART NUMBER:
 31343751050



Roto-Star I purge plug
PART NUMBER:
 31343710090

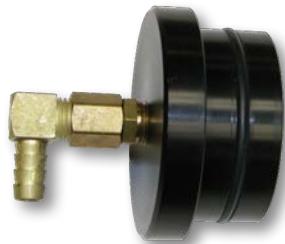

Roto-Star III purge plug
PART NUMBER:
 31343710100

Part Number	Description
31343710010	12" surface plate for Roto-Star I with chuck
31343710030	16" surface plate for Roto-Star III with chuck
31343751050	Variable speed foot pedal with control box
31343710090	Roto-Star I purge plug
31343710100	Roto-Star III purge plug

GRIT BELT GRINDERS



GRIT by FEIN - modular-assembly belt grinding machines that are ideally suited to applications in metal processing and finishing.

GX 75 BELT GRINDER

Universal belt grinder, can be expanded through modules, for metalworking manual trades, ideal for machining stainless steel in small-scale volume production.

BELT GRINDER

GRIT GX 75/GX 75 2H

GX 75 2H	79012209400
GX 75 2H 2V	79012209233
Base	99001010001

Includes: 1 grinding belt 3x79 in (75x2,000 mm), 36 grit R (Must purchase a base to operate. Base part number: 99001010001)

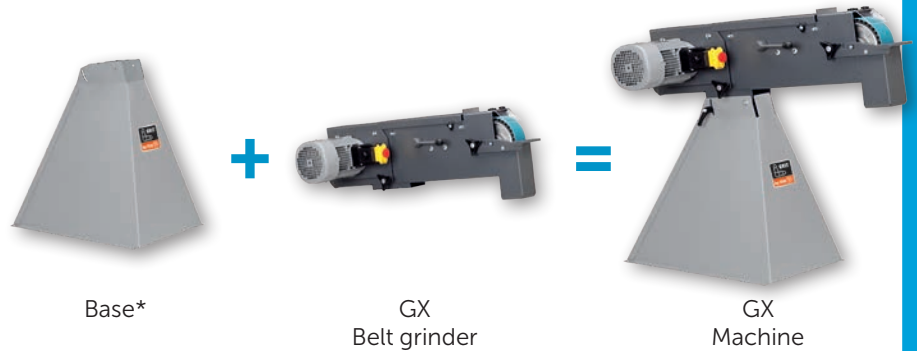

Model	GRIT GX 75 2H and GX 75 2H 2V
Power consumption	1.5/2kW, (220V) or (440V), 3 phase
No-load speed	1,730 / 3,450 rpm
Belt dimensions	3x79 in (75x2,000 mm)
Weight	165 lbs. (75 kg)
Part numbers	79012209400 , GX 75 2H, 440V, 3ph, 2 speed 79012209233 , GX 75 2H, 2V, 220V, 3ph, 2 speed

* Must purchase a base to operate. † Plug ends not included.

GX GRINDING BELTS - 3" W x 79" L

GRIT GRINDING MEDIA R

Extra heavy polyester fabric, full resin bond with zirconium aluminum oxide. Additional top layer for cooling during the grinding process. **Recommended for: stainless, aluminum, alloy steel, coated materials**

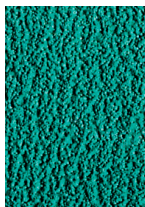

Grit	Pack	3x79 in (75x2,000 mm)
24	10	69903000000
36	10	69903002000
40	10	69903004000
60	10	69903007000
80	10	69903009000
120	10	69903013000

GRIT GRINDING MEDIA Z

Heavy polyester fabric, full resin bond with zirconium aluminum oxide. **Recommended for: steel**

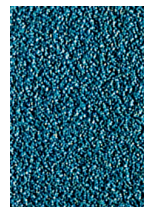

Grit	Pack	3x79 in (75x2,000 mm)
36	10	69903003000
40	10	69903005000
60	10	69903008000
80	10	69903010000
120	10	69903014000

GRIT GRINDING MEDIA A

Heavy cotton fabric, full resin bond with corundum.



Grit	Pack	3x79 in (75x2,000 mm)
220	10	69903017000
320	10	69903018000
400	10	69903019000

GRIT GRINDING MEDIA R

Reliable for elimination of minor defects through to perfect finishes. Long service life ensures cost-effective work. Suitable for GRIT GX 75, GRIT GXC, GRIT GI 75, GRIT GI 150, GRIT GIC, GRIT GIL and GRIT GILS. Also suitable for wet grinding.

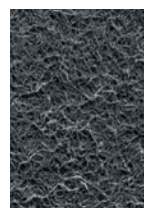

Grit	Pack	3x79 in (75x2,000 mm)
Very fine (blue)	3	69903121010
Medium (red)	3	69903119010
Coarse (brown)	3	69903117010
Assorted pack*	1	69903122010

GX 75 NOTCHING BELT GRINDER

Notching grinding module for exact-fit grinding of pipe, profiles and flat materials.

NOTCHING GRINDER GRIT GX 75/GX 75 2H + GXR

GX 75 2H	79012209400
GX 75 2H 2V	79012209233
GXR	99001001110
Base	99001010001

Includes: 1 ea, contact roller dia; 1-11/16 in pipe (42.4 mm) and 1-7/8 in pipe (48.3 mm); 1 dust container; 1 grinding belt 3 x 88-9/16 in, grit 36 R

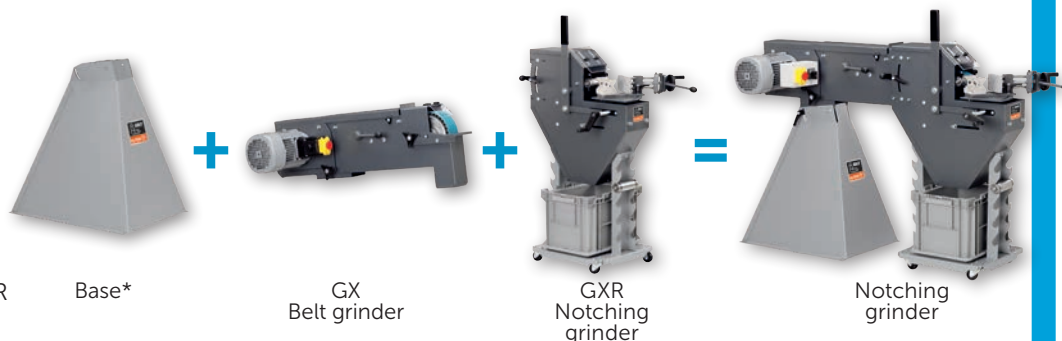

Model	GRIT GXR - Notching Module
Tube diameters	5/8 - 3 in (16 - 75 mm)
Max. dimensions of profile/flat material	3x3 in (75x75 mm)
Belt dimensions	3 x 88-9/16 in (75x2,250 mm)
Weight	119 lbs. (54 kg)
Part number	9900100111z0

* Must purchase a base to operate. † Plug ends not included.



GXR TUBE DIAMETER ROLLERS

Part number	Diameter	Part number	Diameter
69902020000	5/8"	69902061000	1-5/8"
69902024000	3/4"	69902067000	1-3/4"
69902029000	7/8"	69902074000	2"
69902034000	1"	69902080000	2-1/4"
69902043000	1-1/8"	69902084000	2-3/8"
69902048000	1-1/4"	69902086000	2-1/2"
69902052000	1-3/8"	69902090000	2-3/4"
69902057000	1-1/2"	69902095000	3"



GXR PIPE DIAMETER ROLLERS*

Part number	Diameter
69902027000	1/2"
69902040000	3/4"
69902050000	1"
69902062000	1-1/4"
69902071000	1-1/2"
69902084000	2"
69902091000	2-1/2"

*Special diameters available by request.

GXR GRINDING BELTS - 3" W x 88-9/16" L

GRIT GRINDING MEDIA R

Extra heavy polyester fabric, full resin bond with zirconium aluminum oxide. Additional top layer for cooling during the grinding process. **Recommended for: stainless, aluminum, alloy steel, coated materials**

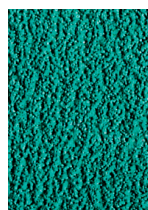

Grit	Pack	3x88 ⁹ / ₁₆ in (75x2,250 mm)
36	10	6 99 03 020 00 0

GRIT GRINDING MEDIA Z

Heavy polyester fabric, full resin bond with zirconium aluminum oxide. **Recommended for: steel**

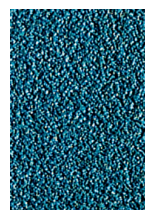

Grit	Pack	3x88 ⁹ / ₁₆ in (75x2,000 mm)
36	10	6 99 03 021 00 0

GRIT BELT GRINDERS



GRIT by FEIN - modular-assembly belt grinding machines that are ideally suited to applications in metal processing and finishing.

GXC 75 CENTERLESS GRINDER

Centerless finishing module for perfect surfaces on ferrous, non-ferrous and stainless tubular materials.

CENTERLESS GRINDER

GRIT GX 75/GX 75 2H + GXC + GXW

GX 75 2H	79012209400
GX 75 2H 2V	79012209233
GXC **	79012309443
GXW cooling system	79012409443
Base	99001010001

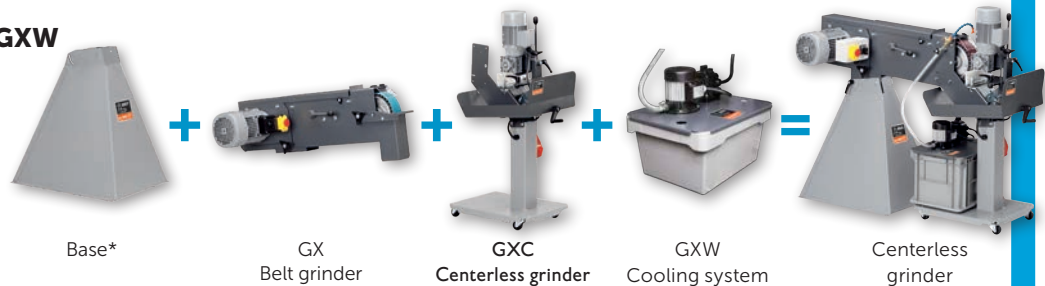

Includes: 2 guide rails nylon,
1 guide rail, brass

Model	GRIT GXC - Centerless Grinding Module
Feed motor power	.28 kW
Feed rate	0–6.5 ft/min (0–2 m/min)
Tube diameters	$\frac{3}{8}$ –4 in (10–100 mm)
Belt dimensions	3 x 79 in (75x2,000 mm)
Weight	106 lbs. (48 kg)
Part number	79012309443, (440 V*)

* Must purchase a base to operate. ** Field converted for 220V. † Plug ends not included.

GXC GRINDING BELTS - 3" W x 79" L

GRIT GRINDING MEDIA R

Extra heavy polyester fabric, full resin bond with zirconium aluminum oxide. Additional top layer for cooling during the grinding process. **Recommended for: stainless, aluminum, alloy steel, coated materials**

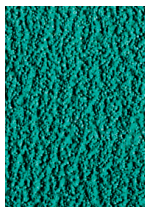

Grit	Pack	3x79 in (75x2,000 mm)
24	10	69903000000
36	10	69903002000
40	10	69903004000
60	10	69903007000
80	10	69903009000
120	10	69903013000

GRIT GRINDING MEDIA Z

Heavy polyester fabric, full resin bond with zirconium aluminum oxide. **Recommended for: steel**

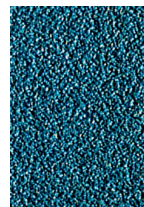

Grit	Pack	3x79 in (75x2,000 mm)
36	10	69903003000
40	10	69903005000
60	10	69903008000
80	10	69903010000
120	10	69903014000

GRIT GRINDING MEDIA A

Heavy cotton fabric, full resin bond with corundum.



Grit	Pack	3x79 in (75x2,000 mm)
220	10	69903017000
320	10	69903018000
400	10	69903019000

GRIT GRINDING MEDIA R

Reliable for elimination of minor defects through to perfect finishes. Long service life ensures cost-effective work. Suitable for GRIT GX 75, GRIT GXC, GRIT GI 75, GRIT GI 150, GRIT GIC, GRIT GIL and GRIT GILS. Also suitable for wet grinding.

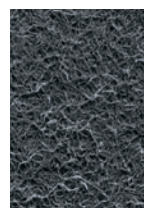

Grit	Pack	3x79 in (75x2,000 mm)
Very fine (blue)	3	69903121010
Medium (red)	3	69903119010
Coarse (brown)	3	69903117010
Assorted pack*	1	69903122010



GXE DEBURRING MACHINE

Effective deburring machine for metalworking trades and small production runs.

DEBURRING MACHINE GRIT GXE + GIXS/GIXBE ¹

GXE 2V	79010509233
GXE	79010109443
GIX (base)	99001002000

Includes: Safety switch; low voltage breaker
(Base not included) - Base part numbers:
GIX (standard base) - 99001002000
GIXBE (Dust extraction base) - 99001009000

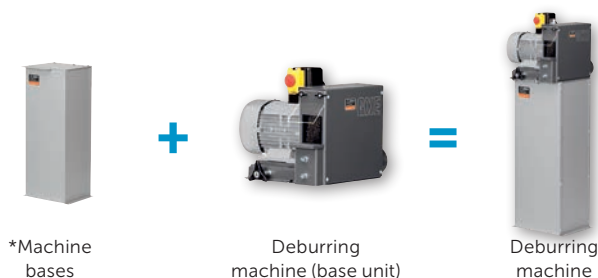

Model	GRIT GXE ¹
Power	2.2 kW
Speed	1,730 rpm
Max. wheel dimensions	9 7/8 x 2 3/8 in (250 x 60 mm) ¹
Power cord	7 ft (2 m)
Weight	71 lbs. (32 kg)
Part numbers	79010509233 (230 V), 79010509443 (440 V)

* Must purchase a base to operate. ¹ Brushes not included. ‡ Plug ends not included.

GXE WIRE WHEELS

WIRE WHEELS

10" x 2 3/8" (250x60 mm) dia., with high strength wire for especially efficient use, mounting hole 2" (51mm) dia.
33 wire gauge for thin-walled pipes and profiles. 29 wire gauge for thick-walled pipes and profiles.

Steel:



Wire thickness	Part number
33 gauge (0.20 mm)	69902006000
29 gauge (0.35 mm)	69902007000
25 gauge (0.50 mm)	69902008000

Stainless steel:



Wire thickness	Part number
33 gauge (0.20 mm)	69902009000
29 gauge (0.35 mm)	69902010000

GRIT BELT GRINDERS



GRIT by FEIN - modular-assembly belt grinding machines that are ideally suited to applications in metal processing and finishing.

GI 150 BELT GRINDER - 6" HEAVY DUTY GRINDER

High performance belt grinder, modular expansion capability, for industrial and production applications. Two speeds, ideal for processing stainless steel.

BELT GRINDER

**GRIT GI 75/GI 75 2H/
GI 150/GI 150 2H + GIB/GIBE**

GI 150 2H	79020509443
GI 150 2H 2V	79020509233
GIB (base)	99001003030
GIBE (dust extraction base)	99001004040



Machine bases*



GI Belt grinder



GI Belt grinder

Model	GI 150 2H
Power	2.6/3.1 kW, (220V or 440V) 3 ph
No-load speed	1,730/3,450 rpm
Belt dimensions	6" x 79" (150 x 2000mm)
Belt speed	49/98 ft/sec (15/30 m/sec)
Weight	181 lbs. (82 kg)
Includes	1 - 6" x 79" 36 grit belt
Part numbers	79020509443 * GI 150 2H, 440V 3ph, 2 speed 79020509233 * GI 150 2H 2V, 3ph, 2 speed

* Must purchase a base to operate. † Plug ends not included.

GI GRINDING BELTS - 6" W x 79" L

GRIT GRINDING MEDIA R

Extra heavy polyester fabric, full resin bond with zirconium aluminum oxide. Additional top layer for cooling during the grinding process. **Recommended for: stainless, aluminum, alloy steel, coated materials**

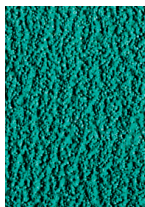

Grit	Pack	6x79 in (150x2,000 mm)
24	10	69903039000
36	10	69903040000
40	10	69903042000
60	10	69903044000
80	10	69903046000
120	10	69903048000

GRIT GRINDING MEDIA Z

Heavy polyester fabric, full resin bond with zirconium aluminum oxide. **Recommended for: steel**

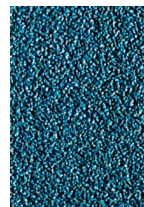

Grit	Pack	6x79 in (150x2,000 mm)
36	10	69903041000
40	10	69903043000
60	10	69903045000
80	10	69903047000
120	10	69903049000

GRIT GRINDING MEDIA A

Heavy cotton fabric, full resin bond with corundum.

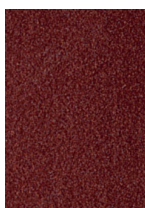

Grit	Pack	6x79 in (150x2,000 mm)
220	10	69903050000
320	10	69903051000
400	10	69903052000

GRIT GRINDING MEDIA R

Reliable for elimination of minor defects through to perfect finishes. Long service life ensures cost-effective work. Suitable for GRIT GX 75, GRIT GXC, GRIT GI 75, GRIT GI 150, GRIT GIC, GRIT GIL and GRIT GILS. Also suitable for wet grinding.

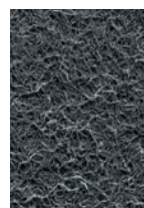

Grit	Pack	6x79 in (150x2,000 mm)
Very fine (blue)	3	69903120010
Medium (red)	3	69903118010
Coarse (brown)	3	69903116010
Assorted pack*	1	69903123010

GX 150 NOTCHING BELT GRINDER - 6" HEAVY DUTY GRINDER

Notching grinding module for exact-fit grinding of pipe, profiles and flat materials.

NOTCHING GRINDER

GRIT GI 150/GI 150 2H + GXR

GI 150 2H	79020509443
GI 150 2H 2V	79020509233
GIR	99001007110
GIB (base)	99001003030
GIBE (dust extraction base)	99001004040

Includes: 1 contact roller 1-11/16 in pipe (42.4 mm) dia.; 1 dust container; 1 grinding belt 6 x 88 9/16 in (150x2,250 mm), grit 36 R

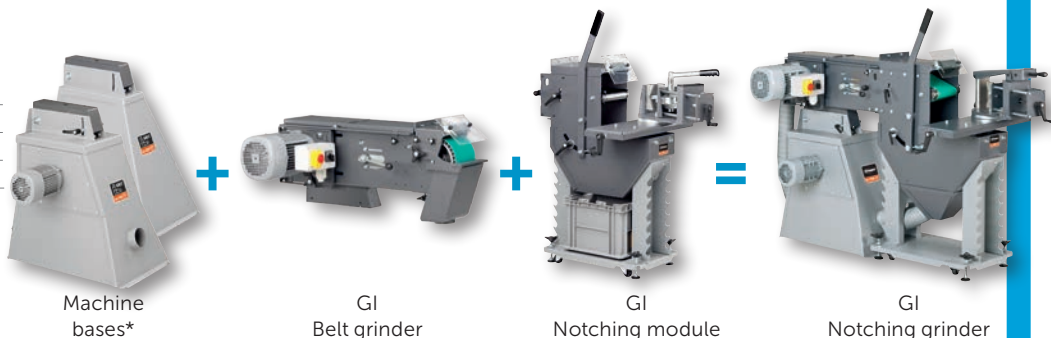

Model	GRIT GIR - Notching Module
Tube diameters	5/8-6 in (20-150 mm)
Max. dimensions of profile/flat material	4 3/4-6 in (120x150 mm)
Belt dimensions	6 x 88 9/16 / 6 x 94 in (150x2,250/150x2,400 mm) with contact rollers over 6 in (150 mm) dia. and mitre grinding plate
Weight	241 lbs (109 kg)
Part number	99001007110

* Must purchase a base to operate. † Plug ends not included.



GXR TUBE DIAMETER ROLLERS

Part number	Diameter	Part number	Diameter
69902101000	3/4"	69902125000	3"
69902104000	1"	69902128000	4"
69902108000	1-1/4"	69902131000	4-1/2"
69902110000	1-3/8"	69902292000	5"
69902113000	1-1/2"	69902132000	5-1/2"
69902116000	1-3/4"		
69902119000	2"		
69902122000	2-1/2"		



GXR PIPE DIAMETER ROLLERS

Part number	Diameter	Part number	Diameter
69902193000	1/2"	69902128000	3-1/2"
69902105000	3/4"	69902131000	4"
69902109000	1"	69902292000	4-1/2"
69902115000	1-1/4"	69902133000	5"
69902117000	1-1/2"	69902134000	6"
69902121000	2"		
69902245000	2-1/2"		
69902127000	3"		

*Special diameters available by request.

GXR GRINDING BELTS - 6" W x 88-9/16" L

GRIT GRINDING MEDIA R

Extra heavy polyester fabric, full resin bond with zirconium aluminum oxide. Additional top layer for cooling during the grinding process. **Recommended for: stainless, aluminum, alloy steel, coated materials**

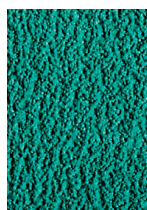

Grit	Pack	6x88 9/16 in (150x2,250 mm)
36	10	69903053000

GRIT GRINDING MEDIA Z

Heavy polyester fabric, full resin bond with zirconium aluminum oxide. **Recommended for: steel**

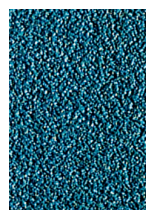

Grit	Pack	6x88 9/16 in (150x2,250 mm)
36	10	69903054000

GRIT BELT GRINDERS



GRIT by FEIN - modular-assembly belt grinding machines that are ideally suited to applications in metal processing and finishing.

GIC 150 CENTERLESS BELT GRINDER

Centerless grinding module for industrial volume production.

CENTERLESS GRINDER GRIT GI 150/GI 150 2H + GIB + GIC + GXW

GI 150 2H	79020509443
GI 150 2H 2V	79020509233
GIC **	79021209443
GXW (coolant tank)	79012409443
GIB (base)	99001003030

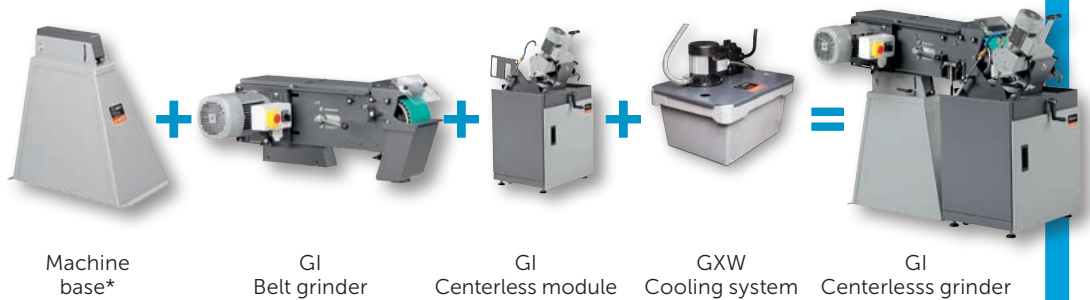

Includes: 2 guide rails nylon,
1 guide rail brass.

Model	GRIT GIC
Power	.18 kW
Tube diameters	$\frac{3}{8}$ to 5 $\frac{1}{8}$ in (10–130 mm)
Tube length	12 in - 20 ft (300–6,000 mm)
Feed rate	0–6.5 ft/min (0–2 m/min)
Belt dimensions	6 x 79 in (150 x 2000 mm)
Weight	143 lbs (65 kg)
Part number	79021209443, (440V*)

* Must purchase a base to operate. † Plug ends not included. ** Field converted for 220V.

GX GRINDING BELTS - 6" W x 79" L

GRIT GRINDING MEDIA R

Extra heavy polyester fabric, full resin bond with zirconium aluminum oxide. Additional top layer for cooling during the grinding process. **Recommended for: stainless, aluminum, alloy steel, coated materials**

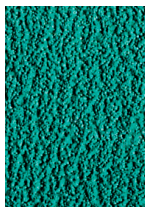

Grit	Pack	6x79 in (150x2,000 mm)
24	10	69903039000
36	10	69903040000
40	10	69903042000
60	10	69903044000
80	10	69903046000
120	10	69903048000

GRIT GRINDING MEDIA Z

Heavy polyester fabric, full resin bond with zirconium aluminum oxide. **Recommended for: steel**

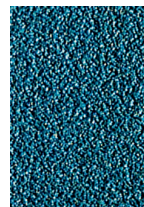

Grit	Pack	6x79 in (150x2,000 mm)
36	10	69903041000
40	10	69903043000
60	10	69903045000
80	10	69903047000
120	10	69903049000

GRIT GRINDING MEDIA A

Heavy cotton fabric, full resin bond with corundum.



Grit	Pack	6x79 in (150x2,000 mm)
220	10	69903050000
320	10	69903051000
400	10	69903052000

GRIT GRINDING MEDIA R

Reliable for elimination of minor defects through to perfect finishes. Long service life ensures cost-effective work. Suitable for GRIT GX 75, GRIT GXC, GRIT GI 75, GRIT GI 150, GRIT GIC, GRIT GIL and GRIT GILS. Also suitable for wet grinding.

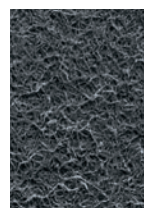

Grit	Pack	6x79 in (150x2,000 mm)
Very fine (blue)	3	69903120010
Medium (red)	3	69903118010
Coarse (brown)	3	69903116010
Assorted pack*	1	69903123010

GKS 75 COMPACT BELT GRINDER

COMPACT BELT GRINDER GRIT GKS 75

GKS 75 79050209232

Includes: 1 grinding belt 3 x 79 in (75x2,000 mm), 36 grit R



Model	GRIT GKS 75
Power consumption	1.1kW, (230V)
No-load speed	3,450 rpm
Belt dimensions	3 x 79 in (75 x 2,000 mm)
Weight	99 lbs. (45 kg)
Part number	79050209232

GX GRINDING BELTS - 3" W x 79" L

GRIT GRINDING MEDIA R

Extra heavy polyester fabric, full resin bond with zirconium aluminum oxide. Additional top layer for cooling during the grinding process. **Recommended for: stainless, aluminum, alloy steel, coated materials**

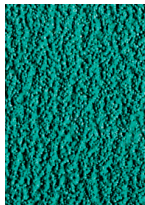

Grit	Pack	3 x 79 in (75 x 2,000 mm)
24	10	69903000000
36	10	69903002000
40	10	69903004000
60	10	69903007000
80	10	69903009000
120	10	69903013000

GRIT GRINDING MEDIA Z

Heavy polyester fabric, full resin bond with zirconium aluminum oxide. **Recommended for: steel**

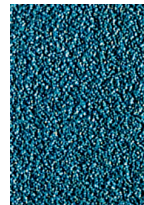

Grit	Pack	3 x 79 in (75 x 2,000 mm)
36	10	69903003000
40	10	69903005000
60	10	69903008000
80	10	69903010000
120	10	69903014000

GRIT GRINDING MEDIA A

Heavy cotton fabric, full resin bond with corundum.

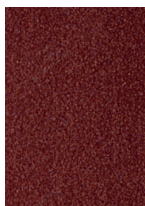

Grit	Pack	3 x 79 in (75 x 2,000 mm)
220	10	69903017000
320	10	69903018000
400	10	69903019000

GRIT GRINDING MEDIA R

Reliable for elimination of minor defects through to perfect finishes. Long service life ensures cost-effective work. Suitable for GRIT GX 75, GRIT GX C, GRIT GI 75, GRIT GI 150, GRIT GI C, GRIT GIL and GRIT GILS. Also suitable for wet grinding.

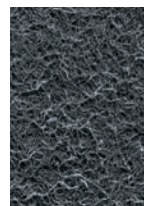

Grit	Pack	3 x 79 in (75 x 2,000 mm)
Very fine (blue)	3	69903121010
Medium (red)	3	69903119010
Coarse (brown)	3	69903117010
Assorted pack*	1	69903122010

GRIT BELT GRINDERS



GRIT by FEIN - modular-assembly belt grinding machines that are ideally suited to applications in metal processing and finishing.

GIMS 75 MOBILE BELT GRINDER

MOBILE BELT GRINDER GRIT GIMS 75

GIMS 75 7 902 13 09 44 3

Includes: 1 grinding belt 3 x 79 in (75 x 2,000 mm), 36 grit R



Model	GIMS 75
Power	4 kW, 440V 3 ph
No-load speed	3,400 rpm
Belt dimensions	3 x 79 in (75x2,000 mm)
Belt speed	98 ft/sec (30 m/sec)
Weight	220 lbs. (100 kg)
Part numbers	79021309443*

GIMS GRINDING BELTS - 3" x 79"

GRIT GRINDING MEDIA R

Extra heavy polyester fabric, full resin bond with zirconium aluminum oxide. Additional top layer for cooling during the grinding process. **Recommended for: stainless, aluminum, alloy steel, coated materials**

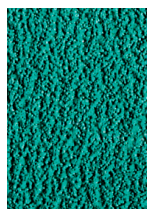

Grit	Pack	3 x 79 in (75 x 2,000 mm)
24	10	69903000000
36	10	69903002000
40	10	69903004000
60	10	69903007000
80	10	69903009000
120	10	69903013000

GRIT GRINDING MEDIA Z

Heavy polyester fabric, full resin bond with zirconium aluminum oxide. **Recommended for: steel**

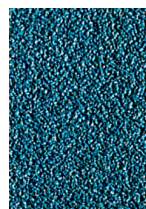

Grit	Pack	3 x 79 in (75 x 2,000 mm)
36	10	69903003000
40	10	69903005000
60	10	69903008000
80	10	69903010000
120	10	69903014000

GRIT GRINDING MEDIA A

Heavy cotton fabric, full resin bond with corundum.

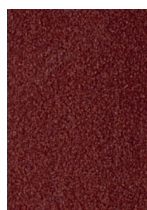

Grit	Pack	3 x 79 in (75 x 2,000 mm)
220	10	69903017000
320	10	69903018000
400	10	69903019000

GRIT GRINDING MEDIA R

Reliable for elimination of minor defects through to perfect finishes. Long service life ensures cost-effective work. Suitable for GRIT GX 75, GRIT GXC, GRIT GI 75, GRIT GI 150, GRIT GiC, GRIT GIL and GRIT GILS. Also suitable for wet grinding.

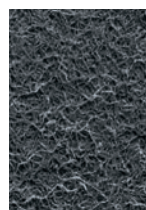

Grit	Pack	3 x 79 in (75 x 2,000 mm)
Very fine (blue)	3	69903121010
Medium (red)	3	69903119010
Coarse (brown)	3	69903117010
Assorted pack*	1	69903122010

3-YEAR WARRANTY

Register your FEIN or SLUGGER by FEIN products today to extend your warranty.

REGISTER AND LOCK IN THE WARRANTY.

FEIN power tools undergo hard field testing before their market launch. We are proud of the cutting-edge technology of our tools and we are confident that we sell users reliable power tools that they will find useful for many years.

By extending our warranty period with the 3-year FEIN PLUS warranty, we make it even clearer why you will work more easily and successfully with FEIN.

OBTAINING THE 3-YEAR FEIN PLUS WARRANTY IS EXTREMELY EASY:

1. REGISTER your new FEIN power tool online within 3 months of purchase. Register conveniently via your personal my.FEIN account.
2. You immediately receive a warranty certificate that entitles you to enjoy the 3-year FEIN PLUS warranty. The warranty certificate is automatically saved in your my.FEIN account.

**REGISTER YOUR
FEIN POWER
TOOL NOW!**



LEARN MORE ABOUT THESE NEW TOOLS & MORE FROM FEIN



PAGE 15
**18V F-IRON
JIG 26 AS**
Cordless jigsaw



PAGE 23
**ASCM 18-4
QMP AS**
4-speed cordless
drill/driver



PAGE 47
VersaMAG
Permanent
magnet vise



PAGE 39
F IRON CUT 57 AS
6" cordless metal
cutting saw

FEIN US
FEIN Power Tools Inc.
1000 Omega Drive,
Suite 1180, Pittsburgh, PA 15205
Toll Free: 1-800-441-9878
www.feinus.com

Printed in the US. Product images are for illustrative purposes only. Technical details subject to change. PN: 69908112182 1.2025 US

